



*Member of the FM Global Group*

# **Approval Standard for Diesel Engine Fire Pump Drivers**

**Class Number 1333**

**December 2008**

---

# Foreword

The FM Approvals certification mark is intended to verify that the products and services described will meet FM Approvals' stated conditions of performance, safety and quality useful to the ends of property conservation. The purpose of Approval Standards is to present the criteria for FM Approval of various types of products and services, as guidance for FM Approvals personnel, manufacturers, users and authorities having jurisdiction.

Products submitted for certification by FM Approvals shall demonstrate that they meet the intent of the Approval Standard, and that quality control in manufacturing shall ensure a consistently uniform and reliable product. Approval Standards strive to be performance-oriented. They are intended to facilitate technological development.

For examining equipment, materials and services, Approval Standards:

- a) must be useful to the ends of property conservation by preventing, limiting or not causing damage under the conditions stated by the Approval listing; and
- b) must be readily identifiable.

Continuance of Approval and listing depends on compliance with the Approval Agreement, satisfactory performance in the field, on successful re-examinations of equipment, materials, and services as appropriate, and on periodic follow-up audits of the manufacturing facility.

FM Approvals LLC reserves the right in its sole judgment to change or revise its standards, criteria, methods, or procedures.

---

# Table of Contents

<b>1. INTRODUCTION .....</b>	<b>1</b>
1.1 Purpose .....	1
1.2 Scope .....	1
1.3 Basis for Requirements .....	1
1.4 Basis for Approval .....	2
1.5 Basis for Continued Approval .....	2
1.6 Effective Date .....	2
1.7 System of Units .....	2
1.8 Applicable Documents .....	3
1.9 Definitions .....	3
<b>2. GENERAL INFORMATION .....</b>	<b>6</b>
2.1 Product Information .....	6
2.2 Approval Application Requirements .....	6
2.3 Requirements for Samples for Examination .....	7
<b>3. GENERAL REQUIREMENTS .....</b>	<b>7</b>
3.1 Review of Documentation .....	7
3.2 Physical or Structural Features .....	7
3.3 Instrumentation and Controls .....	8
3.4 Starting System .....	10
3.5 Charging System .....	11
3.6 Cooling System .....	11
3.6.1 Liquid Cooling .....	11
3.6.2 Open Air Cooling .....	12
3.7 Lubrication System .....	12
3.8 Induction System .....	12
3.9 Exhaust System .....	13
3.10 Fuel System .....	13
3.11 Variable Speed Pressure Limiting Control (VSPLC) System .....	13
3.12 Rating the VSPLC Device .....	14
3.13 ECM Features .....	15
3.14 FM Approved Components .....	15
3.15 Markings .....	16
3.16 Manufacturer's Installation, Operation, and Maintenance Instructions .....	16
3.17 Calibration .....	17
3.18 Test Facilities .....	18
3.19 Tolerances .....	18
<b>4. PERFORMANCE REQUIREMENTS .....</b>	<b>18</b>
4.1 Examination .....	18
4.2 Engine Heaters for Liquid Cooled Engines (Water and/or Oil) .....	19
4.3 Inactive Engine Starts .....	20
4.4 Battery Starting .....	20
4.5 Hydraulic Starting .....	21
4.6 Pneumatic Starting .....	21
4.7 Full Power Test – Raw Water Cooling Only – Base Engine without VSPLC .....	21
4.8 Full Power Test – Radiator Cooling Only – Base Engine without VSPLC .....	22
4.9 Hot Starts .....	23
4.10 Speed Controller Stability at Highest Speed .....	23

---

4.11	Speed Controller Overspeed .....	24
4.12	Full Power – Other Speeds (Raw Water Cooling Only) – Base Engine without VSPLC .....	25
4.13	Full Power – Other Speeds (Radiator Cooling Only) – Base Engine without VSPLC .....	25
4.14	Speed Controller Stability at Lowest Speed.....	26
4.15	Variable Speed Pressure Limiting Control (VSPLC) Systems/Components Examination .....	27
4.16	Variable Speed Pressure Limiting Control (VSPLC) System Cycling Tests .....	28
4.17	Variable Speed Pressure Limiting Control (VSPLC) System Operation Test .....	28
4.18	Additional Tests/VSPLC System .....	29
4.19	Warning Switches .....	29
4.20	Battery Contactors.....	29
4.21	Electronic Control Module (ECM) Performance Test .....	29
4.22	Electronic Control Module (ECM) Operation Test.....	30
4.23	Electronic Control Module (ECM) Repeatability Test .....	30
4.24	ECM Indication.....	31
4.25	Fuel Supervisory Signal .....	31
4.26	Reverse Power.....	31
4.27	Controller Compatibility Testing .....	32
4.28	Additional Tests .....	32
<b>5.</b>	<b>OPERATIONS REQUIREMENTS.....</b>	<b>32</b>
5.1	Demonstrated Quality Control Program .....	32
5.2	Facilities and Procedures Audit (F&PA).....	34
5.3	Manufacturer’s Responsibilities.....	34
5.4	Manufacturing and Production Tests .....	34
5.4.1	Test Requirement No. 1 – <i>Performance Test</i> .....	34
5.4.2	Test Requirements No. 2 – <i>VSPLC Performance Test</i> .....	35
	<b>APPENDIX A: Units of Measurement .....</b>	<b>36</b>
	<b>APPENDIX B: FM Approvals Certification Marks .....</b>	<b>37</b>
	<b>APPENDIX C: Figure.....</b>	<b>39</b>
	<b>APPENDIX D: Sample Listing .....</b>	<b>40</b>
	<b>APPENDIX E: Tolerances.....</b>	<b>41</b>

## 1. INTRODUCTION

### 1.1 Purpose

- 1.1.1 This standard states Approval criteria for diesel engines used to drive fire pumps that supply water to fire protection systems. These diesel engines must have an extended service life, throughout which they must be capable of operating reliably at rated power and speeds during emergency fire incidents, despite being idle for extended periods.
- 1.1.2 Approval criteria include, but are not limited to, performance requirements, marking requirements, examination of manufacturing facility(ies), audit of quality assurance procedures, and a follow-up program.
- 1.1.3 Approval standards are intended to verify that the product described shall meet stated conditions of performance, safety, and quality useful to the ends of property conservation.

### 1.2 Scope

- 1.2.1 This standard encompasses the design and performance requirements for diesel engines used in fire pump service that are designed and installed in accordance with FM Global Property Loss Prevention Data Sheets.
- 1.2.2 This Standard does not address National or Local Codes which require specific emission levels to be met by stationary diesel engine installations.
- 1.2.3 Accessories such as a Variable Speed Pressure Limiting Control System may be examined within the scope of this Approval Standard.
- 1.2.4 This standard encompasses mechanical speed controller (governor style), in addition to electronic fuel management systems.
- 1.2.5 This standard encompasses diesel engines that are normally aspirated, turbocharged, twin turbocharged, and those fitted with aftercoolers.
- 1.2.6 This standard encompasses diesel engines with liquid cooling or open air cooling.
- 1.2.7 This standard encompasses diesel engines with operating speeds at or below 3600 rpm. Typical engine speeds are: 1000, 1200, 1450, 1800, 2100, 2400, 2600, 2800, 3000, and 3600 rpm.
- 1.2.8 Newly developed accessories will be examined on a case-by-case basis.

### 1.3 Basis for Requirements

- 1.3.1 The requirements of this standard are based on experience, research and testing, and/or the standards of other organizations. The advice of manufacturers, users, trade associations, jurisdictions and/or loss control specialists was also considered.
- 1.3.2 The requirements of this standard reflect tests and practices used to examine characteristics of diesel engines for the purpose of obtaining Approval. Diesel engines having characteristics not anticipated by this standard may be FM Approved if performance equal, or superior, to that required by this standard is demonstrated, or if the intent of the standard is met. Alternatively, diesel engines which meet all of the requirements identified in this standard may not be FM Approved if other conditions which adversely affect performance exist or if the intent of this standard is not met.

#### 1.4 Basis for Approval

Approval is based upon satisfactory evaluation of the product and the manufacturer in the following major areas:

1.4.1 Examination and tests on production samples shall be performed to evaluate:

- The suitability of the product;
- The performance of the product as specified by the manufacturer and required by FM Approvals; and,
- As far as practical, the durability and reliability of the product.

1.4.2 An initial facilities and procedures audit shall be conducted to evaluate the manufacturer's ability to consistently produce the product that was examined and tested as part of the Approval project. The audit shall review the facility and in-place quality control procedures used in the manufacturing of the product. Typically, areas of review are incoming inspection, work in progress, production testing, final quality control, marking, calibration of equipment, shipping procedures, and document and drawing control. These examinations are repeated periodically as part of the FM Approvals' product follow-up program. (Refer to Section 5.2, Facility and Procedures Audit.)

#### 1.5 Basis for Continued Approval

Continued Approval is based upon:

- Production or availability of the product as currently FM Approved;
- The continued use of acceptable quality assurance procedures;
- Satisfactory field experience;
- Compliance with the terms stipulated in the Master Agreement;
- Satisfactory re-examination of production samples for continued conformity to requirements; and
- Satisfactory Facilities and Procedures Audits (F&PAs) conducted as part of the FM Approvals' product follow-up program.

Also, as a condition of retaining Approval, manufacturers may not change a product or service without prior written authorization by FM Approvals. (Refer to Section 5.1.3 for further details regarding changes.)

#### 1.6 Effective Date

The effective date of an Approval standard mandates that all products tested for Approval after the effective date shall satisfy the requirements of that standard. Products FM Approved under a previous edition shall comply with the new version by the effective date or forfeit Approval.

The effective date of this standard is **December 31, 2009** for compliance with all requirements.

#### 1.7 System of Units

Units of measurement used in this standard are United States (U.S.) customary units. These are followed by their arithmetic equivalents in International System (SI) units, enclosed in parentheses. The first value stated shall be regarded as the requirement. The converted equivalent value may be approximate. Appendix A lists the selected units and conversions to SI units for measures appearing in this standard. Conversion of U.S. customary units is in accordance with the Institute of Electrical and Electronics Engineers (IEEE)/American Society for Testing and Materials (ASTM) SI 10-2002, *American National Standard for Use of the International System of Units (SI): The Modern Metric System*.

## 1.8 Applicable Documents

The following standards, test methods, and practices are referenced in this standard or are beneficial in understanding this standard:

ASTM D 975-2003, *Standard Specification for Diesel Fuel Oils*

FM Approvals, Approval Standard 1321/1323-2007, *Fire Pump Controllers for Electric Motor and Diesel Engine Drivers*

FM Global Property Loss Prevention Data Sheets

IEEE/ASTM SI 10-2002, *American National Standard for Use of the International System of Units (SI): The Modern Metric System*

National Fire Protection Association (NFPA) 20-2007, *Standard for the Installation of Stationary Pumps for Fire Protection*

NFPA 37-2006, *Standard for the Installation and Use of Stationary Combustion Engines and Gas Turbines*

Society of Automotive Engineers (SAE) Standard J20-2006, *Coolant System Hoses*

SAE Standard J537-2000, *Storage Batteries*

SAE Standard J1349-2004, *Engine Power Test Code – Spark Ignition and Compression Ignition – Net Power Rating*

SAE Standard J819-1987, *Engine Cooling System Field Test (Air-to-Boil) Standard*

## 1.9 Definitions

For purposes of this standard, the following terms apply:

### ***Accepted***

This term refers to installations acceptable to the authority enforcing the applicable installation rules. When the authority is FM Global, such locations are termed “FM Global Accepted.” Acceptance is based upon an overall evaluation of the installation. Factors other than the use of FM Approved equipment impact upon the decision to accept, or not to accept. Acceptance is not a characteristic of a product. It is installation specific. A product accepted for one installation may not be acceptable elsewhere. (Contrast this definition with FM Approved.)

### ***Aftercooler***

This is a type of heat exchanger. The spinning turbocharger heats the inlet air to the engine during the process of compressing it. This heated air then passes through one side of a heat exchanger. Cooling water or atmospheric cooling air passes through the other side of the heat exchanger, cooling the inlet air before it is pushed into the cylinder head. The large temperature reduction in the compressed inlet air, compared with a turbocharged only air supply, provides an increase in power output as a result of a more dense air charge in the cylinder.

### ***Battery Contactor***

For the purpose of this standard a battery contactor is an electrically actuated solenoid that provides a means to electrically connect the battery and the starter motor. The battery contactor carries full cranking current. The contactor should be manually operable and of the snap-action type.

### ***Breakaway Current***

The starter current required to initiate engine rotation during crank. (See rolling current).

### ***FM Approvals Certification Marks***

The FM Approvals Certification Marks are detailed in Appendix B. Their use is mandatory on all units of FM Approved diesel engine fire pump drivers. These registered marks cannot be used except as authorized by FM Approvals via the granting of Approval to a specific product.

***Diesel Engine***

An internal combustion engine in which the fuel is ignited entirely by the heat resulting from the compression of the air supplied for combustion. (See direct and indirect injection below.)

***Direct Injection***

A fuel system where fuel is injected directly into the cylinder where the complete combustion cycle takes place.

***ECM***

Electronic Control Modules (ECM) are electronic systems that manage engine performance. See Section 3 for complete requirements.

***Fire Pump Controller***

For the purpose of this Approval standard, a group of devices that serve to control, in some predetermined manner, the starting and stopping of the fire pump driver as well as monitoring and signaling the status and condition of the fire pump package.

***Fire Pump Package***

An assembled unit consists of a fire pump, driver, controller, and accessories.

***Flexible Drive Coupling***

A device used to connect the shafts or other torque-transmitting components from a driver to the pump. The device shall not rely on the elastomeric or polymeric element as a sole means of torque transmission without having metal-to-metal contact of components to drive the pump in case of elastomeric or polymeric element failure. The coupling assembly shall permit minor angular and parallel misalignment as restricted by both the pump and coupling manufacturers.

***FM Approved***

This term refers to products FM Approved by FM Approvals. Such products are listed in the Approval Guide, an online resource of FM Approvals. All products so listed have been successfully examined by FM Approvals, and their manufacturers have signed and returned a Master Agreement to FM Approvals. The Master Agreement obligates the manufacturer to allow re-examination of the product and audit of facilities and procedures at FM Approval's discretion. It further requires the manufacturer not to deviate from the as-FM Approved configuration of the product without review by and agreement of FM Approvals. Approval is product specific.

***Full Load (Full Power)***

The dynamometer load corresponding to the maximum sustainable power output, corrected for ambient air pressure and temperature, as determined in Section 3.2.1.

***Grade Number 1-D Fuel***

An ASTM designated grade of diesel fuel oil described as a special-purpose, light distillate fuel for automotive diesel engines in applications requiring higher volatility than that provided by Grade Number 2-D fuels.

***Grade Number 2-D Fuel***

An ASTM designated grade of diesel fuel oil described as a special-purpose, middle distillate fuel for automotive diesel engines, which is also suitable for use in non-automotive applications, especially in conditions of frequently varying speed and load.

***Grade Number 4-D Fuel***

An ASTM designated grade of diesel fuel oil described as a heavy distillate fuel, or a blend of distillate and residual oil, for low-and medium-speed diesel engines in non-automotive applications involving predominantly constant speed and load.

***Hollow Shaft***

This pertains to the hollow vertical drive shaft of electric motors or right angle gear drives used to drive vertical turbine pumps. The hollow drive shaft is designed to accept the solid line shaft of the pump. The design facilitates impeller adjustment within the bowl assembly and the installation of a non-reverse ratchet into the motor or gear drive.

***Indirect Injection***

A fuel system where fuel is injected into a combustion chamber sometimes referred to as a pre-combustion chamber that is remote from the cylinder and connected to the cylinder via a gas passage. The fuel is injected into the pre-combustion chamber where combustion begins, then passes through the gas passage to the cylinder where the combustion process is completed. Indirect Injection engines shall not be allowed for this service.

***Line Shaft***

A shaft which transmits the power from the driver to the pump shaft.

***Liquid Cooled Engine***

For the purposes of this standard, a liquid cooled engine shall be defined as any engine utilizing raw water to cool the primary coolant of the engine (oil or water). The engine is then cooled by circulation of the primary coolant.

***Maximum Power***

The greatest speed-corrected power required to drive the pump at rated speed and at any point along pump's characteristic curve, and through the pump's total run-out condition.

***Mechanical Governor***

A mechanical device which maintains a manually adjustable set point to obtain the operating speed of the engine.

***Non-Reverse Ratchet***

A mechanism installed as an integral part of the hollow shaft electric motor or hollow shaft right angle gear drive to prevent reverse rotation of the pump-driver assembly.

***Radiator Cooled***

For the purposes of this standard, a radiator cooled engine shall be defined as any engine utilizing air to cool the primary coolant of the engine (oil or water). The engine is then cooled by circulation of the primary coolant.

***Raw Water Cooled***

For the purposes of this standard, a raw water cooled engine shall be defined as any engine using raw water to cool the primary coolant of the engine (oil or water). The engine is then cooled by circulation of the primary coolant. (See liquid cooled engine.)

***Rated Power***

The power resulting from the calculation of full load power times a de-rating factor in order to account for reliability of performance and for normal deterioration of output over anticipated service life. This is discussed in detail in Section 3.2.2.

***Rated Pressure***

The pressure at which the sprinkler system is designed and installed. This is normally 175 psi (1205 kPa) unless specifically specified otherwise.

***Rolling Current***

The starter current that is required to maintain engine rotation during crank (see breakaway current).

***Set Pressure***

For Variable Speed Pressure Limiting Control (VSPLC) service, set pressure is the pressure at which the control circuit is factory set. At any sprinkler system pressure higher than this set point, the diesel engine shall start to slow from the factory preset rated speed.

***System Pressure***

The pressure that the fire pump and relief valve, in concert, maintain in the sprinkler system piping at any flow condition.

***Variable Speed Pressure Limiting Control (VSPLC)***

The VSPLC system is an accessory package which is manufacturer mounted and manufacturer set on a standard FM Approved diesel engine, and which shall initially operate only when a feedback signal indicates that pressure in the sprinkler system is greater than the set pressure of the pressure limiting device. The accessory package then acts to slow diesel engine speed, which thereby slows the fire pump, and as a consequence reduces pump discharge pressure. When the pump discharge pressure is at or less than the set pressure for which the accessory package is manufacturer preset, the accessory package disengages, and diesel engine speed control is returned to the engine speed controller. A data plate on the diesel engine shall indicate the lowest speed that the variable speed control system shall reduce engine speed to, and the set pressure for engagement of the accessory package.

## **2. GENERAL INFORMATION**

### **2.1 Product Information**

- 2.1.1 Diesel engine fire pump drivers are expected to perform reliably under normal application conditions for a minimum of 2,000 hours or five years without an overhaul, whichever comes first. Each engine shall provide its full rated power throughout its service life.
- 2.1.2 All FM Approved engines shall operate on diesel fuel meeting one of the grades as defined in ASTM Standard D 975, Grades 1-D, 2-D, or 4-D, or an internationally recognized equivalent. The engines shall be of the direct injection type. The use of glow plugs shall not be allowed. Spark ignited internal combustion engines shall not be allowed.
- 2.1.3 In order to meet the intent of this standard, diesel engine fire pump drivers must be examined on a model-by-model, type-by-type, manufacturer-by-manufacturer, and plant-by-plant basis. This is predicated on the basis that identical designs, fabricated in identical materials by different manufacturers or, even by different plants of the same manufacturer, have been seen to perform differently in testing. Sample diesel engine fire pump drivers, selected in conformance to this criterion, shall satisfy all of the requirements of this standard.

### **2.2 Approval Application Requirements**

- 2.2.1 To apply for an Approval examination the manufacturer, or its authorized representative, should submit a request to:

Group Manager - Hydraulics  
FM Approvals  
Member of the FM Global Group  
743A Reynolds Road  
West Glocester, RI 02814 USA

- 2.2.2 The manufacturer shall provide the following preliminary information with any request for Approval consideration:
- A complete list of all models, configurations [normally aspirated (NA), turbocharged (TC), twin turbocharged (TCAC), or twin turbocharged with aftercoolers (TCAC)], speed control systems (ECM or mechanical), cooling system, operating speeds, and voltage (12V or 24V) for the products or services being submitted for Approval consideration;
  - The number and location of manufacturing facilities.
- 2.2.3 All documents shall identify the manufacturer's name, document number or other form of reference, title, date of last revision, and revision level. All foreign language documents shall be provided with English translation.

### 2.3 Requirements for Samples for Examination

Following set-up and authorization of an Approval examination, the manufacturer shall prepare samples for examination and testing. Sample requirements are to be determined by FM Approvals following review of the preliminary information. Sample requirements may vary depending on design features, results of prior testing, and results of the foregoing tests. It is the manufacturer's responsibility to submit samples representative of production. Any decision to use data generated utilizing prototypes is at the discretion of FM Approvals. The manufacturer shall provide the test facilities, which are required to evaluate the diesel engine fire pump drivers.

## 3. GENERAL REQUIREMENTS

### 3.1 Review of Documentation

During the initial investigation and prior to physical testing, the manufacturer's specifications, technical data sheets, and design details shall be reviewed to assess the ease and practicality of installation and use. The product shall be capable of being used within the limits of the Approval investigation. These documents shall be controlled as outlined in the Manufacturer's Quality Assurance Plan.

### 3.2 Physical or Structural Features

- 3.2.1 Power outputs determined by testing, per Sections 4.7 (Full Power Test - Raw Water Cooling Only - Base Engine without VSPLC), 4.8 (Full Power Test - Radiator Cooling Only - Base Engine without VSPLC), 4.12 (Full Power - Other Speeds (Raw Water Cooling Only) - Base Engine without VSPLC) and 4.13 (Full Power - Other Speeds (Radiator Cooling Only) - Base Engine without VSPLC), shall be adjusted to standard conditions to compensate for changes in volumetric efficiency by use of the formula:

$$P_{sc} = P_t \times \left( \frac{29.61}{P_a} \right) \times \sqrt{\frac{T + 460}{77 + 460}}$$

$$P_{sc} = \frac{1.278 \times P_t \times \sqrt{(T + 460)}}{P_a}$$

Where:

- $P_{sc}$  - Actual power at 300 feet above sea level, standard atmospheric conditions of 77°F and 29.61 inches of Mercury (Full Load Power)
- $P_t$  - Power obtained in testing under atmospheric conditions of  $P_a$  and T
- $P_a$  - Ambient pressure in inches of Mercury
- T - Air inlet or ambient air temperature in degrees Fahrenheit

The equivalent formula for International System units of measure is:

$$P_{sc} = P_t \times \left( \frac{100.3}{P_a} \right) \times \sqrt{\frac{(T + 273.2)}{25 + 273.2}}$$

$$P_{sc} = \frac{5.808 \times P_t \times \sqrt{(T + 273.2)}}{P_a}$$

Where:

- $P_{sc}$  - Actual power at 91 m above sea level, standard atmospheric conditions of 25°C and 100.3 kPa (Full Load Power)
- $P_t$  - Power obtained in testing under atmospheric conditions of  $P_a$  and T
- $P_a$  - Ambient pressure in kPa
- T - Air inlet or ambient air temperature in degrees Celsius

These formulas are based on the ideal gas laws. (Reference SAE J1349).

- 3.2.2 The desired rated power output for each fire pump driver is increased by 10 percent to determine the actual power required in testing to justify that rating. The relations are:

$$P_{sc} = 1.1 \times \text{Rated Power or } \text{Rated Power} = P_{sc} / 1.1$$

This 10 percent power overrating is required to allow for reliability of performance and for normal deterioration of output over the anticipated service life.

- 3.2.3 Horsepower rating adjustments for installation conditions are made for increased elevation and increased operating temperature in accordance with NFPA 20-2007, Sections 11.2.2.4 and 11.2.2.5, plus Graphs A11.2.2.4 and A11.2.2.5.
- 3.2.4 The diesel engine fire pump drivers shall be arranged to allow power takeoff from a stub shaft or flange-mounted to the engine's rotating element. The power takeoff must be designed to allow the working space required to service a fire pump when a fire pump is connected directly to an engine. If a flexible drive coupling is used, it shall not have a center element that is elastomeric or polymeric without having metal-to-metal contact of components to drive the pump in case of center element failure. The coupling assembly shall permit minor angular and parallel misalignment as restricted by both the pump and coupling manufacturers.

### 3.3 Instrumentation and Controls

- 3.3.1 The following minimum instrumentation shall be installed in a panel and mounted on the engine by the manufacturer:
- A. A tachometer shall be provided to indicate engine speed. If the tachometer is not of the totalizing type, a separate hour meter shall be provided to indicate total time of operation.
  - B. An oil pressure gauge shall be provided to indicate engine lubricant pressure.

- C. Liquid-cooled and radiator cooled engines shall be equipped with a temperature gauge to monitor the primary coolant loop temperature. Air-cooled engines shall also be equipped with a temperature gauge to monitor either the lubricant temperature or the engine's external surface temperature in the area nearest the point of combustion.
  - D. When electrical starting is used, a gauge shall be provided to indicate either charging system current direction and magnitude (an ammeter) or state of charge of each battery (a voltmeter). If pneumatic starting is used, this instrument shall be replaced by a pressure gauge on the air reservoir.
  - E. Unless locally mounted elsewhere on the engine (e.g. ECM), all required control devices, starting and shut-down switches, and indicator lamps shall be mounted in an engine instrument panel. Any locally mounted devices must be securely fastened to the engine, readily accessible, and wired to the instrument panel. The instrument panel shall not be used as a junction box or conduit for any wiring that is not part of the fire pump package (e.g. AC wiring, louver wiring, pump room heating power or controls, etc). The instrument panel shall be securely mounted to the engine by the manufacturer in a location that does not subject operating personnel to unreasonable hazard from hot surfaces or moving parts of the engine, pump, belt drives, or power transmission equipment. Mounting shall be such as to protect the instrumentation from the effects of vibration, heat, or mechanical damage.
  - F. The engine wiring outside the instrument panel shall be harnessed, attached, protected and/or enclosed to minimize mechanical, thermal, or engine fluid damage. The use of protective coverings or cable trays is required to satisfy this requirement. Tensions in individual wires shall be eliminated. The wiring shall be connected to terminals in the instrument panel that correspond to the standard scheme shown in Appendix C. All wiring and circuits providing signals to the controller shall be rated for 10 Amps (minimum).
- 3.3.2 Each FM Approved engine shall be equipped with an adjustable speed controller to maintain the engine speed within plus or minus 10 percent of each FM Approved speed. The speed controller shall be pre-set by the manufacturer to provide the required regulation at the FM Approved speed for which the particular engine is ordered.
- 3.3.3 An overspeed shutdown switch shall be provided to shut down a diesel engine which attempts to exceed 110-120 percent of its nominal manufacturer pre-set rated speed as recommended by the engine manufacturer. The switch shall require manual resetting prior to restarting the diesel engine. An indication of overspeed shutdown shall be provided on the engine panel, and an overspeed signal shall be provided to the controller.
- 3.3.4 A cooling system high temperature switch shall be provided to monitor one of the temperatures specified in Section 3.3.1 C. This temperature switch shall be arranged to close at a temperature level indicating inadequate engine cooling.
- 3.3.5 A lubricant low pressure switch shall be provided and arranged to close at a lubricant pressure level that indicates inadequate engine lubrication.
- 3.3.6 An adjustable manual throttle shall be provided. It shall be designed to provide positive locking for any setting, such that tools are required either for access to the adjustment or to actually make the speed adjustment. If an electronic speed switch is supplied, it shall be mounted inside the instrument panel. Other tamper-resistant measures can be considered for Approval if they provide equivalent security against accidental or unauthorized re-adjustment of the speed setting.
- 3.3.7 Engines shall be supplied with a speed-sensitive switch to signal when the engine is running, for the purposes of crank termination.
- 3.3.8 The control circuits of the engine and the controller shall operate on either 12 Volt D.C. or 24 Volt D.C. The engine is not required to be capable of switching between 12 and 24 Volt power supply.

- 3.3.9 Electronic fuel management controls are permitted. They must have dual electronic control modules (ECM) which control the fuel injection process. Both the primary and alternate ECM devices shall be hard mounted, programmed and wired so that full engine power shall still be available in the event of failure of the primary ECM. The engine, including the primary ECM, shall not continuously draw current in excess of 0.5 Amps during stand-by.

### 3.4 Starting System

- 3.4.1 Engines that have an electrical starting system shall have the capacity to provide a minimum six minute (15 seconds continuous cranking followed by 15 seconds of rest, repeated 12 times) cycle at full rated cranking speed at 40 °F (4.5 °C) ambient temperature. Termination of cranking, when initiated by an automatic controller, shall be controlled by a crank-speed monitoring device or other means of affording equivalent reliability of start monitoring. The starting system shall be compatible with FM Approved automatic controllers, see Figure C-1 in Appendix C, and shall also allow manual emergency starting in the event of controller failure.
- 3.4.2 The manufacturer shall specify the capacities of all auxiliary equipment required for starting, even when such equipment is to be provided by others. This auxiliary equipment includes storage batteries, air reservoirs, connecting cables, piping, etc. When storage batteries are required for starting, two identical batteries shall be specified, each capable of independently providing 6 of the 12 cranking cycles discussed in Section 3.4.1. Batteries shall, at a minimum, be rated for 900 cold cranking amps at 0°F (-18°C) and shall have a reserve capacity of at least 430 min. when evaluated in accordance with SAE Standard J537. Batteries shall be sized considering the maximum parasitic loads allowed by NFPA20 for the engine, controller, and other pump room equipment. Other starting methods shall provide equivalent redundancy of starting energy storage.
- 3.4.3 FM Approved electrical automatic controllers provide alternate starts on alternate batteries, so a design using battery starting shall include all necessary contactors and wiring. Alternatively, the monitoring system shall note the level of charge on both batteries, and select the battery with the highest level of charge remaining.
- 3.4.4 Pneumatic starting systems shall include all necessary solenoid valves and other interfacing devices for connection to a FM Approved automatic controller. The system shall have an air capacity to permit 180 seconds of continuous cranking without recharging. Suitable supervisory service shall indicate high and low air pressure conditions.
- 3.4.5 In addition to responding to signals from an FM Approved controller, all devices required for emergency starting using either battery shall also be operable by direct manual means. Engines with only one cranking motor shall include a battery contactor installed between each battery and the cranking motor for battery isolation. Battery contactors shall be manually operable and of the snap-action type. Engines with two cranking motors shall have one cranking motor dedicated to each battery. Each cranking motor shall have an integral solenoid relay to be operated by the controller. Each cranking motor solenoid relay shall be capable of being energized from a manual operator on the engine panel. The engine fuel and cooling water supply valves shall be manually operable, or manual by-pass valves shall be installed. All manual starting devices shall be labeled as specified in Section 3.15.
- 3.4.6 Hydraulic starting systems shall provide not fewer than six cranking cycles such that during each cycle the engine shall carry its full rated load within 20 seconds after cranking is initiated, with air intake, room ambient air temperature, and the hydraulic cranking system all at 32 °F (0 °C). Suitable electrical supervisory service shall monitor and provide the stored hydraulic pressure within the predetermined pressure limits.

### 3.5 Charging System

All starting systems shall be rechargeable by both engine-driven and auxiliary devices. The systems shall be arranged so that a FM Approved controller maintains fully charged starting energy reservoirs by means of the auxiliary recharging device.

### 3.6 Cooling System

The cooling system shall automatically maintain the engine within its desirable range of operating temperatures. The manufacturer shall state the desired normal operating temperature range of the engine in the operation manual.

#### 3.6.1 Liquid Cooling

- A. Liquid cooling systems shall have a closed primary loop. The heat from the primary loop shall be dissipated directly to a secondary, open, raw water cooling circuit, or to an air cooled radiator. Thermostats are permitted in the closed loop. Thermostats shall be readily replaceable. Liquid cooling systems shall be provided with an opening in the primary loop for replenishing coolant or checking the liquid level. An expansion reservoir shall also be provided to eliminate loss of coolant due to thermal expansion and contraction when the system has been properly filled. All liquid-cooled engines shall be equipped with a jacket water heater capable of maintaining the primary coolant temperature at 120 °F (49 °C). Elastomeric hose that meets or exceeds the requirements of SAE Standard J20, Class R1, *Coolant System Hoses* shall be used. If water filled, the engine manufacturer shall define the type and amount of anti-freeze and/or additives to be mixed with primary coolant water for the best protection and the suggested interval for replacement.
- B. When a vee belt is used to drive the coolant circulating pump, the pump drive shall include two or more belts, or two or more vees on a single belt. Belt(s) shall be suitably guarded to protect operating personnel from injury.
- C. If a raw water secondary coolant is used, the manufacturer shall provide a graph of required flow and pressure versus raw water temperature for each engine and speed submitted for Approval. Raw water inlet and outlet connections shall be pipe-threaded in conformance with the recognized national standard of the country to which the engine is to be delivered. The raw water outlet shall be at least one pipe size larger than the inlet. These requirements shall apply to aftercoolers as well, even when these represent the only use of raw water.
- D. Supplemental cooling devices such as lubricant and inlet air coolers shall be permitted if they share raw water supplies with the primary engine cooling systems as defined in Section 3.6.1.C or 3.6.2.B. Aftercoolers may, however, be cooled by a separate raw water flow, even if the main cooling system does not use raw water.
- E. When engine oil is used as the heat exchange medium in the primary loop, no water pump or expansion reservoir is necessary. The lubrication oil pump or a separate oil pump shall be provided to circulate the heat transfer medium oil. The oil may be cooled in a raw water or cross-flow air heat exchanger. An engine cooled by an air heat exchanger shall be provided with a connection to duct the cooling air exhaust outside the room in which the engine is installed. An engine cooled by an air heat exchanger shall be compatible with the pressure drops of the air supply and discharge ventilators defined in NFPA 20, Section 11.3.2.3

### 3.6.2 Open Air Cooling

- A. The heat from the primary loop shall be dissipated directly to the atmosphere by a radiator, engine operated fan and circulating pump, and an engine jacket temperature regulating device. The fan and other moving parts shall be suitably guarded to protect operating personnel from injury.
- B. Supplemental cooling devices such as lubricant and inlet air coolers shall be permitted if they share cooling air supplies with the primary engine cooling systems as defined in Section 3.6.2.D. Aftercoolers may be cooled by raw water flow from the fire pump, even if the main cooling system is air cooled. Aftercoolers may also be cooled by an air to air heat exchanger using air provided by the radiator fan and discharged along with the air discharged from the radiator or by coolant from the primary coolant loop.
- C. Primary loop cooling systems shall be provided with an opening in the primary loop for replenishing coolant or checking the liquid level. An expansion reservoir shall also be provided to eliminate loss of coolant due to thermal expansion and contraction when the system is properly filled. All liquid-filled primary cooling loops shall be equipped with a jacket water heater capable of maintaining the primary coolant at 120 °F (49 °C). Elastomeric hose that meets or exceeds the requirements of SAE Standard J20, Class R1, *Coolant System Hoses* shall be used. If water filled, the engine manufacturer shall define the type and amount of anti-freeze to be mixed with primary coolant water for the best protection, and the suggested interval for replacement.
- D. If the primary coolant heat is to be dissipated directly to the atmosphere, engine-driven means shall be provided for positive movement of air through the heat exchanger. The heat exchanger shall be designed to maintain normal engine operating temperatures, and not to allow coolant boil-out, with a minimum room air temperature of 120 °F (49 °C) at the combustion air cleaner inlet. A connection shall be provided to duct the coolant air exhaust outside the room in which the engine is installed.
- E. Air supply and discharge ventilators shall be in conformance with the requirements of NFPA 20, Section 11.3.2.3.

## 3.7 Lubrication System

- 3.7.1 Engines shall be equipped with a suitable, pressure-type lubrication system, comprised of a direct engine-driven pump, a filter, and a distribution system. It shall have adequate capacity to maintain lubricant temperatures within the range recommended by the lubricant manufacturer and the engine manufacturer. The lubrication system shall be free of visible leakage. The lubricant filter media shall be readily replaceable or the filter shall be of a permanent type allowing ready cleaning. Means for checking, draining, and replenishing lubricant supply shall be provided. Any lubrication system vents shall be capable of being equipped with connections to duct the vent fumes outside of the engine room and to filter the incoming venting air.
- 3.7.2 The manufacturer's recommendations for oil heaters shall be followed. If in-sump heaters are not allowed by the diesel engine manufacturer, then FM Approved heat tracing equipment may be considered on the outside of the lower engine block and oil pan area.

## 3.8 Induction System

The air-intake or induction system shall be equipped with a suitable filter to prevent dust and debris from entering the engine. The filter shall be designed for easy replacement or cleaning of the filtering media. The air filter shall maintain its integrity after becoming wet, or shall be covered with an impact and heat resistant spray shield or housing suitable for preventing damage and water ingestion by the engine from an operating overhead or sidewall sprinkler.

If the manufacturer's installation instructions allow or require air intake to the engine to be supplied via a duct from outside the engine room; the engine manufacturer shall provide requirements for air cleaner sizing and duct sizing. Each diesel engine fire pump driver in a multiple engine room shall have an independent air-intake system. The manufacturer's recommendations for cleaning and changing air filters shall be followed, during testing and in field installations.

### 3.9 Exhaust System

The exhaust system shall be gas tight throughout the operating range of exhaust temperatures and pressures. It shall be designed with an outlet connection to readily duct exhaust gases outside the engine room and away from air-intake systems. The system shall be sized in accordance with the manufacturer's recommendations, and arranged to preclude the entry of water into the pump room. The exhaust manifold and turbocharger housing (when provided by the drive manufacturer) shall be suitably guarded, insulated, or cooled to prevent fire hazards and injury to operators. Each diesel engine fire pump driver in a multiple engine room shall have an independent exhaust system.

### 3.10 Fuel System

3.10.1 The fuel system shall include a fuel filter with readily replaceable filter media. The fuel system shall be leak-free throughout all conditions of engine operation. The inlet to the fuel system shall be readily connectable to a fuel supply line employing connections designed in accordance with a recognized standard of the nation to which the engine is to be delivered.

- A. The fuel system supply and return size shall be specified by the manufacturer.
- B. The diesel fuel shall be as specified on the diesel engine data plate supplied by the manufacturer.
- C. The fuel tank capacity shall be recommended by the manufacturer, or the pump packager, subject to modification by local prevailing conditions, such as refill cycle, and availability of specified fuel. For installations where FM Global is the authority having jurisdiction Property Loss Prevention data Sheet 3-7 shall be consulted for additional requirements on fuel tanks, fuel lines, fuel tank location and construction.

3.10.2 There shall be a separate fuel line and a separate fuel supply tank for each engine.

3.10.3 Exposed fuel lines shall be guarded or protected to prevent kinking or impact damage, and suitably supported to minimize vibration, which could cause fatigue stress and subsequent fuel line failure.

3.10.4 Engines that employ a DC electric motor driven fuel pump shall be allowed provided they incorporate an automatic bypass method for the fuel and provided that the engine is capable of producing rated power in the event of failure of the electric motor driven fuel pump.

### 3.11 Variable Speed Pressure Limiting Control (VSPLC) System

The accessory package may be a hydraulically or electronically controlled feedback system which attaches to the diesel engine. It shall lower engine speed when the pump discharge pressure exceeds a predetermined set pressure, and shall not function when the pump discharge pressure does not exceed set pressure. In case of failure of the VSPLC system, it shall fail in a manner which allows the engine's speed controller to control the engine normally, at the full rated manufacturer set speed of the diesel engine. The VSPLC system shall include the following operating characteristics:

3.11.1 The VSPLC device shall not decrease engine speed unless the pump discharge pressure exceeds the set pressure.

- 3.11.2 The VSPLC device shall have a set pressure that is adjusted by the manufacturer. The set pressure shall be non-field adjustable and tamper-proof.
- 3.11.3 It shall not be possible for the VSPLC device to increase engine speed above manufacturer set speed for the purpose of increasing system pressure.
- 3.11.4 The VSPLC device shall begin to decrease the rated set speed of the engine at a pump discharge pressure of no less than 100 percent of set pressure, or no more than 105 percent of set pressure.
- 3.11.5 The VSPLC equipped engine shall meet the acceleration requirements of Section 4.3.
- 3.11.6 If the VSPLC device is a mechanical assembly, it shall conform to the following requirements:
- A. Moving and sliding parts shall be made from compatible corrosion-resistant materials, or shall be equipped with bushings, inserts, or bearings made from these materials, to ensure freedom of motion;
  - B. Interior threads shall be bronze or other equivalent corrosion-resistant material;
  - C. Interior springs shall be made from material having corrosion resistance equivalent to phosphor bronze, and shall not be susceptible to stress corrosion;
  - D. Clearance shall be provided between working parts and between working and stationary parts so that corrosion or foreign deposits shall not result in sluggish action, or otherwise impair operation of the VSPLC device;
  - E. If an orifice with a diameter less than 0.187 inches (4.7 mm) is used in a VSPLC device, a screen or strainer with corrosion resistance equivalent to brass shall be provided. The total area of the openings shall be not less than 20 times the cross-sectional area of the opening that the screen or strainer is to protect. The largest opening in the screen or strainer shall not exceed 0.032 inch (0.8 mm) less than the protected orifice;
  - F. The standard connection from the pump discharge to the VSPLC device shall be 1/2 in. NPT minimum;
  - G. The VSPLC device shall fail in the de-energized position, such that the engine continues to run at full rated speed.
  - H. A system overpressure indicator shall actuate at 115 percent of set pressure.

### 3.12 Rating the VSPLC Device

A “Z” factor shall be calculated for each speed at which a listed engine is FM Approved. It can be determined as follows:

$$Z = 1 - (N_2/N_1)^2$$

Where:

$N_1$  - the factory set rated speed of the engine in RPM

$N_2$  - the reduced engine speed in RPM

With the VSPLC device fully engaged “Z” can be multiplied by the maximum pressure on the pump speed corrected curve to obtain the maximum amount of trim pressure available using the VSPLC device:

$$P_{\text{trim}} = Z \times P_{\Delta}$$

Where:

- $P_{\text{trim}}$  - the maximum amount of pressure that can be trimmed from the system pressure with the VSPLC device engaged
- $P_{\Delta}$  - the shutoff pressure developed by the selected pump

The “Z” factor shall be published in the Approval Guide for each FM Approved and listed speed of the diesel engine on which the VSPLC device can be mounted.

### 3.13 ECM Features

- 3.13.1 The ECM engine panel shall have a supervisory signal of low fuel pressure, fuel injection failure, electric motor driven fuel pump failure (if pump is supplied) or primary sensor failure. A signal or signals shall also be sent to the controller in these fault conditions. Other alarms and signals may be sent to the controller if desired.
- 3.13.2 Each ECM equipped engine shall withstand reverse battery power or transient voltage spikes without damage to the ECM.
- 3.13.3 Each ECM equipped engine shall be wired in accordance with Appendix C, including terminals from Number 301 and up.
- 3.13.4 Each ECM shall retain operation settings during battery power interruptions.
- 3.13.5 The operating ECM, plus any other parasitic loads due to engine components shall not draw more than 0.5 amperes in standby mode. Engine current demands in excess of 0.5 amperes are allowed provided they do not exceed 1 minute and do not occur at intervals less than every 6 hours.
- 3.13.6 The engine panel shall contain a manual selector switch for either the primary or alternate ECM. There shall be no off position. If the selector switch is inadvertently moved during engine operation, the engine may stop running. The engine panel shall be able to be reset and the engine shall be able to be manually re-started from the engine panel without delay. An acceptable alternative is an automatic system that switches to the secondary ECM if the primary fails.
- 3.13.7 The engine panel shall show positive indication of failure of either ECM, permitting the operator to manually switch to the back-up ECM.
- 3.13.8 ECM devices that are initialized (powered up) only upon the fire pump controller’s call to start (crank) signal must be properly sequenced with the controller to prevent start/stop signal oscillation. All ECM devices shall employ diodes and relays as necessary to prevent voltage or current backfeed to the controller terminals, and ensure power sequencing compatibility with the fire pump controller. ECM devices shall not require design changes to FM Approved fire pump controllers in order to operate.

### 3.14 FM Approved Components

Whenever FM Approved components (contactors, valves, etc.) are available, these shall be used. Non-FM Approved components must be successfully tested in accordance with their relevant Approval standard prior to authorization of their inclusion on an engine submitted for Approval, where the requirements of that standard are more extensive than the requirements of this standard.

### 3.15 Markings

- 3.15.1 A permanently-marked, legible, corrosion-resistant nameplate shall be securely attached to the diesel engine fire pump driver where it shall be easily visible. The nameplate shall include the minimum following information:
- Manufacturer's name or trademark;
  - Horsepower output rating and manufacturer set engine speed;
  - Model number and serial number;
  - Year of manufacture;
  - FM Approvals Certification Mark, (see Appendix B); and
  - Manufacturing source code where necessary.
- 3.15.2 A data plate on the engine shall describe the type and grade of fuel required by the manufacturer to meet stated engine performance.
- 3.15.3 The VSPLC accessory package or the diesel engine shall carry a data plate which indicates the lowest speed the control system shall reduce the engine speed to, and the set pressure for engagement of the accessory package.
- 3.15.4 Each engine shall also have a similar corrosion-resistant data plate listing the instructions for manual emergency starting prominently displayed. These instructions shall be complete and easily understood, so that an individual with no prior knowledge of the engine's operation shall be able to manually start the engine by following them. Individual controls shall be clearly and unambiguously identified in these instructions and correspondingly labeled on the engine. Instructions on when and how to switch to the alternate ECM shall be included.
- 3.15.5 Any other pertinent marking information required by the national or international standard to which the engine is manufactured shall be permanently marked on a suitable data plate.
- 3.15.6 The model or type identification shall correspond with the manufacturer's catalog designation and shall uniquely identify the product as FM Approved. The manufacturer shall not place this model or type identification on any other product unless covered by a separate agreement.
- 3.15.7 The FM Approvals Certification Mark (see Appendix B) shall be displayed visibly and permanently on the product. The manufacturer shall not use this mark on any other product unless such product is covered by separate agreement with FM Approvals.
- 3.15.8 All markings shall be legible and durable.
- 3.15.9 A temporary tag shall be attached to both terminals, except grounds, to which a battery cable is to be attached stating the capacity of the batteries required.

### 3.16 Manufacturer's Installation, Operation, and Maintenance Instructions

Installation, operation, and maintenance instructions, including any special dimensional requirements, shall be furnished by the manufacturer of the diesel engine, and subsequent parties involved with the packaging of the diesel engine for fire pump service. For each manual provided, the warranty and service contact information shall be clearly identified. Instructions shall be provided with each diesel engine and shall include the following information at minimum:

#### **Installation:**

- Specifications for storage batteries, air reservoirs, or hydraulic feed pressure depending on means of starting and/or cooling the provided diesel engine;
- If flow-through water cooled, diagram of raw water coolant loop and graph of required flow and pressure versus raw water temperature for engine, and aftercoolers, as applicable;

- If oil cooled block with water heat exchanger, diagram of raw water coolant loop and graph of required flow and pressure versus oil operating temperature and raw water temperature for the engine;
- If radiator cooled, estimate of clear area around radiator for free passage of cooling air through the radiator and requirements for air flow volume over time;
- Electrical, hydraulic, or pneumatic schematic drawings showing the connections provided for wiring or piping to FM Approved fire pump controllers;
- Estimated inlet air consumption to air filter;
- Lifting points and mounting recommendations for installation onto common base plate with fire pump;
- Specifications for recommended sizing of the exhaust system;
- Specifications for connecting electrical cables and piping in order to complete installation;
- Stub shaft or flywheel plate dimensions;
- Specifications for valves and pressure regulators for cooling and auxiliary piping lines, and;
- Diagram of fuel system with elevation of fuel tank, specifications for fuel, and any fuel storage time limits as applicable.

**Operation:**

- Instructions for starting and stopping sequences for Auto and Manual mode;
- Description of trouble codes if diesel is electronically controlled;
- Normal operation temperatures for engine coolant and lubricant, and;
- Recommended specification for engine coolant and lubricant.

**Maintenance:**

Recommended service intervals, with descriptions of the service required at each interval shall be clearly identified. A listing of accessories specified for fire pump driver service, including part numbers, capacities, and sizes shall be clearly identified. In the case of purchased parts, the part manufacturer's name and model designation shall also be included. If items of varying capacities are specified, the selection procedure shall be included. The list shall specifically include all service replacement parts as indicated below:

- Cooling system major components (i.e. heat exchanger, radiator, aftercooler);
- Generator or alternator;
- Speed controller;
- Single or dual starters (Specify if left hand or right hand only);
- Supercharger or turbocharger ;
- Major components of fuel injector system (i.e. injectors, fuel pump);
- Instruments on engine control panel;
- Specifications for recommended engine lubricant and coolant;
- Specifications for engine lubricant, fuel, and air filters;
- Specification for vee belts;
- Specification for replacement thermostats, and oil pressure, overspeed shutdown, and temperature switches;
- Specification for main battery contactor(s), (cross-sectional requirements required); and,
- Specifications for the batteries.

**3.17 Calibration**

All equipment used to verify the test parameters shall be calibrated within an interval determined on the basis of stability, purpose, and usage of the equipment. A copy of the calibration certificate for each piece of test equipment is required for FM Approvals records, indicating that the calibration was performed against working standards whose calibration is certified as traceable to the National Institute of Standards and Technology (NIST) or to other acceptable reference standards and certified by a ISO 17025 calibration laboratory. The test equipment must be clearly identified by label or sticker showing the last date of the calibration and the next due date. A copy of the service accreditation certificate as an ISO 17025, "General Requirements for the Competence of Testing and Calibration Laboratories", calibration laboratory is required for FM Approvals records.

The calibration of recently purchased new equipment is also required. Documentation indicating either the date of purchase or date of shipment, equipment description, model and serial number is required for identification. The period from the time the equipment was put into service to the date of testing must be within an interval that does not require the equipment to be calibrated as determined on the basis of the parameters mentioned above.

### **3.18 Test Facilities**

If review of all required information indicates suitability for Approval, testing of sample engines shall be scheduled. The range of tests to be conducted shall be specified by FM Approvals. The manufacturer shall provide facilities and all properly calibrated instrumentation necessary to perform the tests described below, and any other tests deemed necessary by FM Approvals. Accuracy requirements shall be defined by SAE Standard J1349, Engine Power Test Code – Spark Ignition and Compression Ignition – Net Power Rating. If other standards are contemplated, they should be forwarded to FM Approvals for review and acceptance prior to testing. The manufacturer shall also provide personnel to install and operate the engines, and make the required measurements. FM Approvals shall witness the tests and shall receive copies of the data and calibration certificates. All the tests shall be conducted at normal room temperature, except as noted.

### **3.19 Tolerances**

Tolerances on units of measure shall be as described in Appendix E, unless otherwise specified.

## **4. PERFORMANCE REQUIREMENTS**

The manufacturer shall provide facilities and all properly calibrated instrumentation necessary to perform the tests described below, and any other tests deemed necessary by FM Approvals. The manufacturer shall also provide personnel to install and operate the engines, and record the required measurements. A representative of FM Approvals shall witness the tests. Testing shall be performed in the approximate order as stated below. A test that states when it shall be performed in relation to another test must be conducted in the sequence as stated. All tests shall be performed on a complete diesel engine fire pump driver. Components shall not be tested individually, except by prior agreement with FM Approvals. For engines that employ an electric motor driven fuel pump with automatic bypass, power tests shall be performed with the fuel pump disabled and the bypass in use.

Some of the following tests require the connection to and coordinated function with an FM Approved diesel fire pump controller. The FM Approvals project engineer will specify which FM Approved controller is to be used for each investigation project and assist in coordination with the controller manufacturer. Successful operation of the engine in the tests discussed in 4.27 (Controller Compatibility Testing), utilizing this controller, will be considered to be representative of all FM Approved controllers.

#### 4.1 Examination

##### 4.1.1 Requirements

The diesel engine(s) shall conform to the manufacturer's drawings and specifications and to Approval requirements.

##### 4.1.2 Test/Verification

A sample shall be examined and compared to drawings and specifications. It shall be verified that the sample conforms to the physical and structural requirements described in Section 3, General Requirements. The manufacturer shall supply, at a minimum, the following information for each engine model submitted for Approval:

- A. Model designation(s) and speed(s) for which Approval is sought;
- B. Power output versus speed test data for the engine equipped with all fire pump driver accessories required;
- C. Engine instrument panel drawing;
- D. Nameplate, fuel data plate, and starting instruction plate drawings;
- E. Outline dimensional drawing showing all inlet and outlet connections, mounting size (footprint), and locating dimensions;
- F. Secondary coolant requirements per Section 3.6.1.C or Section 3.6.2.D, whichever is applicable;
- G. Desired normal engine operating temperature range as measured by the gauge described in Section 3.3.1.C;
- H. Cooling system flow schematic, (if applicable);
- I. Electrical, hydraulic, or pneumatic schematic drawings showing the connections provided for wiring or piping to FM Approved fire pump controllers;
- J. Dimensional junction box drawing or manifold drawing showing labeled terminals for connection to FM Approved fire pump controllers;
- K. List of all specifications and materials used in construction of the internal parts of the engine, including any special or unusual treatment(s) or fabrication(s);
- L. A review of safety guards which cover moving parts.
- M. General assembly drawings, one complete set of overall package drawings, materials list(s) and physical property specifications, anticipated marking format, brochures, wiring diagrams, cooling loop diagrams, fuel requirements, accessory features, sales literature, specification sheets, installation, operation and maintenance procedures or manuals; and,
- N. Supplied component drawings may be required if not addressed by Installation, Operation and Maintenance Manual.

## 4.2 Engine Heaters for Liquid Cooled Engines (Water and/or Oil)

### 4.2.1 Requirement

The engine heaters shall be able to maintain a 120 °F (49 °C) minimum coolant temperature.

### 4.2.2 Test/Verification

After an exposure of 16 hours minimum at 40 °F (4.5 °C) with the engine off and only the jacket heaters energized, the coolant temperature measured in the jacket at the engine block shall be 120 °F (49 °C) minimum. Test chamber temperature and water temperature shall be verified before the engine is started for the remainder of the testing.

## 4.3 Inactive Engine Starts

### 4.3.1 Requirement

To ensure the engine's ability to start after being idle with the test chamber at 80 °F (27 °C) or less, an inactive engine shall be started, brought to full output horsepower for the manufacturer's defined set speed, and stopped a minimum of three times in rapid succession. The engine shall be inactive, with the jacket water heater disconnected, for 8 hours prior to this test. The engine shall be operated at full power for no more than 20 seconds each time it is started.

### 4.3.2 Test/Verification

An inactive engine (8 hours minimum) shall be started, by battery, hydraulic, or pneumatic means, brought to full output horsepower for the manufacturer's defined set speed, and stopped a minimum of three times in rapid succession. The time to start and reach rated speed (+/- 10 RPM) and power (+/- 2 percent) shall not exceed 20 seconds each time. The time in seconds to start and reach full power shall be measured and reported. At the conclusion of the three cycles, the starting system shall continue to perform satisfactorily.

## 4.4 Battery Starting

### 4.4.1 Requirement

Engines having an electrical starting system shall have the capacity to provide a minimum six minute starting cycle at full rated cranking speed at 40 °F (4.5 °C) ambient temperature. The diesel engine will not have a connection to the fuel supply, and will not be allowed to start during this test. The starter motor shall show no signs of damage, overheating, or failure.

### 4.4.2 Test/Verification

After an exposure of 16 hours minimum at 40 °F (4.5 °C) with the engine off and only the jacket heaters energized, the cranking test shall be conducted. The test shall consist of fifteen seconds of cranking and fifteen seconds of rest for twelve consecutive cycles. The cranking test shall be divided between the two batteries, with cranking periods alternating between the two batteries. The starter motor shall show no signs of damage due to overheating and shall continue to perform satisfactorily after completion of the test. Termination of cranking, when initiated by an automatic controller, shall be governed by a crank-speed monitoring device or other means of affording equivalent reliability of start monitoring. At the conclusion of the test, the starting system shall continue to perform satisfactorily.

#### 4.5 Hydraulic Starting

##### 4.5.1 Requirement

Engines having a hydraulic starting system shall have the capacity to provide a minimum of six cranking cycles. The first three are to be automatic from the signaling source. They shall provide the necessary number of engine revolutions at the required revolutions per minute to permit the engine to meet the requirements of carrying its rated speed (+/- 10 RPM) and power (+/- 2 percent) within 20 seconds after cranking is initiated, with intake air, ambient temperature, and hydraulic cranking system at 32 °F (0 °C). The second three cycles are to be manual, and are to be a single control operated by one person. The diesel engine will not have a connection to the fuel supply, and will not be allowed to start during this test.

##### 4.5.2 Test/Verification

After the engine has been idle for a minimum of 4 hours at 32 °F (0 °C), the cranking test shall be conducted. The test shall consist of six cranking cycles. The first three are to be automatic from the signaling source. They shall provide the necessary number of engine revolutions at the required revolutions per minute to permit the engine to meet the requirements of carrying its full rated load within 20 seconds after cranking is initiated, with intake air, ambient temperature, and hydraulic cranking system at 32 °F (0 °C). The second three cycles are to be manual, and are to be a single control operated by one person. Proper operation of the hydraulic system to provide an interlock to prevent the engine from re-cranking, in the event of failure due to low engine lubrication, over speed and high water jacket temperature shall be verified. The interlock shall be manually reset for automatic starting when engine failure is corrected. At the conclusion of the test, the starting system shall continue to perform satisfactorily.

#### 4.6 Pneumatic Starting

##### 4.6.1 Requirement

Engines having a pneumatic starting system shall have the capacity to provide a minimum of 180 seconds of continuous cranking without recharging. There shall be a separate suitably powered automatic air compressor or some other system independent of an air compressor driven by the diesel engine. Suitable supervisory service shall be maintained to indicate high and low air pressure conditions. A manually operated bypass circuit shall be provided for direct application of air to the engine starter in the event of control circuit failure.

##### 4.6.2 Test/Verification

After the engine has been idle for a minimum of 4 hours at room temperature, conduct a starting test. Engines having a pneumatic starting system shall be subjected to 180 seconds of continuous cranking without recharging. The diesel engine will not have a connection to the fuel supply, and will not be allowed to start during this test. At the conclusion of the test the starting system shall continue to perform satisfactorily. The engine crank speed will not fall below the manufacturer's minimum specification for starting speed, rpm, during the 180 second test.

#### 4.7 Full Power Test – Raw Water Cooling Only – Base Engine without VSPLC

##### 4.7.1 Requirement

The raw water cooled engine shall operate at full power for four hours non-stop at the highest speed requested by the manufacturer for Approval. The engine shall be able to sustain the full power output for the duration of the test. The rated horsepower shall be determined as described in Sections 3.2.1 and 3.2.2, and so listed in the Approval Report.

#### 4.7.2 Test/Verification

The raw water cooled engine, connected to a suitable dynamometer, shall operate at full power for four hours non-stop at the highest speed requested by the manufacturer for Approval. At a minimum, the following data shall be taken at an interval of 15 minutes:

- Rotational speed;
- Power output;
- Ambient air pressure and temperature, or air inlet pressure and temperature;
- Fuel consumption rate;
- Raw coolant inlet and outlet temperatures and flow rate; and
- Lubricant pressure and temperature.

Stable or decreasing coolant temperature, lubricant temperature and fuel consumption, and stable or increasing lubricant pressure are verification that the engine is able to sustain the full power output for the duration of the test.

Any stopping of the engine during the four hour test shall be considered a failure.

The manufacturer may acquire any other performance data that they deem useful, where it does not interfere with power performance of the engine, or collection of the minimum data necessary for the engine Approval program.

### 4.8 Full Power Test – Radiator Cooling Only – Base Engine without VSPLC

#### 4.8.1 Requirement

The radiator cooled engine (with either water or oil as the primary coolant) shall operate at full power for four hours non-stop at the highest speed requested by the manufacturer for Approval. The engine shall be able to sustain the full power output for the duration of the test. The rated horsepower shall be determined as described in Sections 3.2.1 and 3.2.2, and so listed in the Approval Report.

#### 4.8.2 Test/Verification

After the test chamber has been warmed and ambient air temperature stabilized at 120 °F (49 °C) minimum, the radiator cooled engine, connected to a suitable dynamometer, shall operate at full power for four hours non-stop at the highest speed requested by the manufacturer for Approval. The differential pressure between the radiator discharge pressure and test chamber pressure shall be controlled at the maximum differential allowed by the manufacturer's installation instructions. At a minimum, the following data shall be taken at an interval of every 15 minutes:

- Rotational speed;
- Power output;
- Ambient air pressure and temperature, or air inlet pressure and temperature;
- Fuel consumption rate;
- Coolant temperature, and
- Lubricant pressure and temperature.
- Differential pressure between the radiator discharge air pressure and test chamber air pressure

Stable or decreasing coolant temperature, lubricant temperature and fuel consumption, and stable or increasing lubricant pressure are verification that the engine is able to sustain the full power output for the duration of the test.

Any stopping of the engine during the four hour test shall be considered a failure.

The manufacturer may acquire any other performance data that they deem useful, where it does not interfere with power performance of the engine, or collection of the minimum data necessary for the engine Approval program.

Testing at 120°F (49 °C) is preferred, but the procedures in SAEJ819 may be used to ensure the air-to-boil temperature is less than 120 °F (49 °C) and testing performed at other temperatures if 120 °F (49 °C) can not be maintained.

#### 4.9 Hot Starts

##### 4.9.1 Requirement

Immediately after the four hour test at highest speed, three hot starts shall be conducted. The engine shall start, reach, and maintain full power each time. This series of tests shall be repeated after completion of the one hour operational test at the slowest operating speed. Again the engine shall start, reach, and maintain full power each time.

##### 4.9.2 Test/Verification

Immediately following the four hour test, three hot starts shall be conducted. The first shall be within 60 seconds after the engine comes to a full stop. The second and third tests shall each occur after 150 second intervals. The time to reach rated speed (+/- 10 RPM) and power (+/- 2 percent) should not exceed 20 seconds for each cycle. The time between starts and the time in seconds to reach full power shall be recorded and reported for all three starts. The engine should be operated for no more than 30 seconds at full power each time it is started. This series of tests shall be repeated after completion of the one hour operational test at the slowest operating speed. Again the engine shall start, reach, and maintain full power each time.

#### 4.10 Speed Controller Stability at Highest Speed

##### 4.10.1 Requirement

The speed controller shall be able to control the speed within  $\pm 10$  percent of the highest rated speed. The speed shall return to the manufacturer set value each time full power is restored, from an unloaded condition.

##### 4.10.2 Test/Verification

The speed controller of the engine shall be set to maintain rated speed at 100 percent of rated load. The following test shall be conducted at the highest rated speed requested by the manufacturer for Approval, as shown by Figure 4.10.2, Speed controller Stability Test Sequence, after completion of the four hour full power test, and the hot start test, as described in Section 4.7 (Full Power Test - Raw Water Cooling Only - Base Engine without VSPLC), 4.8 (Full Power Test - Radiator Cooling Only - Base Engine without VSPLC), and 4.9 (Hot Starts).

- A. The engine shall be started, brought to full power, and the speed recorded;
- B. The dynamometer load shall be rapidly reduced to zero load, and the speed recorded;
- C. The dynamometer load shall be raised to 25 percent of full power, and the speed recorded;
- D. The dynamometer load shall be rapidly reduced to zero load, and the speed recorded;
- E. The dynamometer load shall be raised to 50 percent of full power, and the speed recorded;
- F. The dynamometer load shall be rapidly reduced to zero load, and the speed recorded;

- G. The dynamometer load shall be raised to 75 percent of full power, and the speed recorded;
- H. The dynamometer load shall be rapidly reduced to zero load, and the speed recorded;
- I. The dynamometer load shall be returned to full power, and the speed recorded.

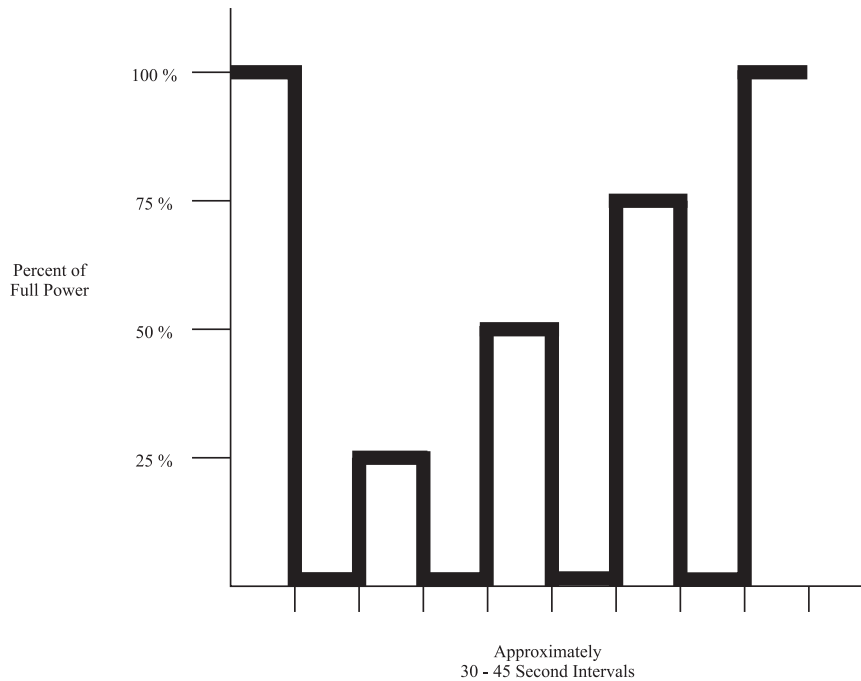

Figure 4.10.2 - Speed Controller Stability Test Sequence

The speed shall return to the manufacturer set value each time full power is restored. The verified recorded engine speed (rev/min) shall not vary by more than  $\pm 10$  percent of the manufacturer set speed at each dynamometer load recorded.

## 4.11 Speed Controller Overspeed

### 4.11.1 Requirement

The overspeed switch shall engage and stop the engine, at an operating speed between 10 and 20 percent above the manufacturer set speed. The overspeed switch shall require manual reset before the engine can be restarted.

### 4.11.2 Test/Verification

The engine shall be brought to full speed. The throttle shall be manually adjusted to cause the operating speed to increase slowly up to 20 percent above the manufacturer set operating speed. The overspeed switch shall engage and stop the engine, at an operating speed between 10 and 20 percent above the manufacturer set speed. Immediately following shutdown it shall be verified that the appropriate voltage has been applied to Terminal 3 (overspeed signal sent to the controller) and proper operation of overspeed indicator on the engine panel. The engine shall then be manually cranked to verify that it cannot be restarted until the overspeed switch is manually reset. If more than one model of overspeed shutdown device is used to cover the full range of speeds requested for Approval for a given engine, each model device shall be tested for at least one Approval speed within its range.

**4.12 Full Power – Other Speeds (Raw Water Cooling Only) – Base Engine without VSPLC****4.12.1 Requirement**

The raw water cooled engine shall be operated at full power non-stop for one hour at each of the lower operating speeds requested by the manufacturer for Approval. The engine shall be able to sustain the full power output for the duration of the test. The rated horsepower shall be determined as described in Sections 3.2.1 and 3.2.2, and so listed in the Approval Report. Coolant temperatures shall remain within the manufacturer's specified range throughout this test with no manual adjustment to the cooling system. Following the one hour test at the slowest operating speed, the diesel engine shall be tested for compliance with Section 4.9 (Hot Starts), and Section 4.14 (Speed Controller Stability at Lowest Speed).

**4.12.2 Test/Verification**

The raw water cooled engine shall be operated at full power, non stop, for one hour at each of the lower operating speeds requested by the manufacturer for Approval. The engine shall be allowed to stabilize at each speed for at least two minutes prior to the data being recorded. The power output data shall be corrected for ambient air pressure and temperature by the formula given in Section 3.2.1. Immediately following this test and at the slowest operational speed, the engine shall be subjected to the post-tests detailed in Section 4.12.1. Data, as detailed below, shall be taken at fifteen minute intervals during these tests:

- Rotational speed;
- Power output;
- Ambient air pressure and temperature, or air inlet pressure and temperature;
- Fuel consumption rate;
- Raw coolant inlet and outlet temperatures and flow rate; and
- Lubricant pressure and temperature.

Stable or decreasing coolant temperature, lubricant temperature and fuel consumption, and stable or increasing lubricant pressure are verification that the engine is able to sustain the full power output for the duration of the test.

**4.13 Full Power – Other Speeds (Radiator Cooling Only) – Base Engine without VSPLC****4.13.1 Requirement**

Radiator cooled engines shall be operated at full power non-stop for one hour at each of the lower operating speeds requested by the manufacturer for Approval. The engine shall be able to sustain the full power output for the duration of the test. The rated horsepower shall be determined as described in Sections 3.2.1 and 3.2.2, and so listed in the Approval Report. Coolant temperatures shall remain within the manufacturer's specified range throughout this test with no manual adjustment to the cooling system. Following the one hour test at the slowest operating speed, the diesel engine shall be tested at the slowest speed for compliance with Section 4.9 (Hot Starts), and Section 4.14 (Speed controller Stability at Lowest Speed).

**4.13.2 Test/Verification**

After the test chamber has been warmed and stabilized to an ambient air temperature of 120 °F (49 °C) minimum, the radiator cooled engine shall be operated at full power, non-stop, for one hour at each of the lower operating speeds requested by the manufacturer for Approval. The engine shall be allowed to stabilize at each speed for at least two minutes prior to the data being recorded. The power output data shall be corrected for ambient air pressure and temperature by the formula given in Section 3.2.1. Immediately following this test at the slowest operational speed, the engine shall be subjected to the

post-tests detailed in Section 4.13.1. Data, as detailed below, shall be taken at fifteen minute intervals during these tests:

- Rotational speed;
- Power output;
- Ambient air pressure and temperature, or air inlet pressure and temperature;
- Fuel consumption rate;
- Coolant temperature; and,
- Lubricant pressure and temperature.
- Differential pressure between radiator discharge air pressure and test chamber air pressure

Stable or decreasing coolant temperature, lubricant temperature and fuel consumption, and stable or increasing lubricant pressure are verification that the engine is able to sustain the full power output for the duration of the test.

#### 4.14 Speed Controller Stability at Lowest Speed

##### 4.14.1 Requirement

The speed controller shall be able to control the speed within  $\pm 10$  percent of the lowest rated speed for which Approval is being requested. The speed shall return to the manufacturer set value each time full power is restored, from an unloaded condition.

##### 4.14.2 Test/Verification

The speed controller of the engine shall be set to maintain the lowest rated speed at 100 percent of rated load. The following tests shall be conducted at the lowest rated speed requested by the manufacturer for Approval, at the completion of the one hour power test at the lowest rated speed, as shown by Figure 4.14.2, Speed Controller Stability Test Sequence.

- A. The engine shall be started, brought to full power, and the speed recorded;
- B. The dynamometer load shall be rapidly reduced to zero load, and the speed recorded;
- C. The dynamometer load shall be raised to 25 percent of full power and the speed recorded;
- D. The dynamometer load shall be rapidly reduced to zero load, and the speed recorded;
- E. The dynamometer load shall be raised to 50 percent of full power and the speed recorded;
- F. The dynamometer load shall be rapidly reduced to zero load, and the speed recorded;
- G. The dynamometer load shall be raised to 75 percent of full power and the speed recorded;
- H. The dynamometer load shall be rapidly reduced to zero load, and the speed recorded;
- I. The dynamometer load shall be returned to full power and the speed recorded.

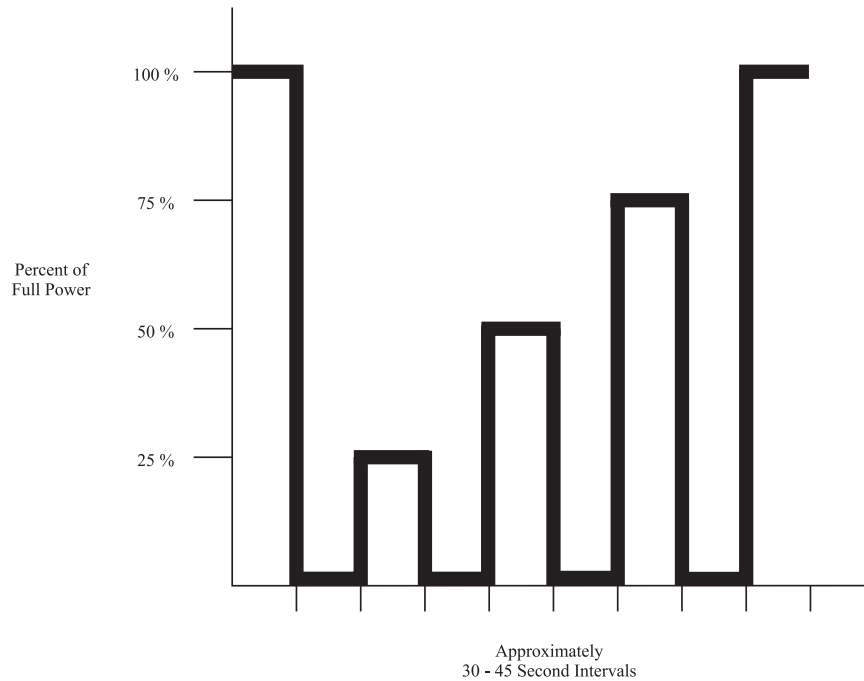

Figure 4.14.2 - Speed Controller Stability Test Sequence

The speed shall return to the manufacturer set value each time full power is restored. The verified recorded engine speed (rev/min) shall not vary by more than  $\pm 10$  percent of the manufacturer set speed each time the dynamometer load is reduced from full power.

#### 4.15 Variable Speed Pressure Limiting Control (VSPLC) Systems/Components Examination

##### 4.15.1 Requirements

Components of the VSPLC system shall first be examined for design concept and materials of construction.

##### 4.15.2 Test/Verification

Depending on construction, the following tests may be conducted: corrosion tests on metallic components; elastomeric compatibility tests on seals; or fatigue tests on springs. Hydrostatic pressure tests shall be conducted on pressure containing parts as appropriate. The hydraulic or electronic feedback circuit shall be independently cycle tested either as an assembly, or as components, depending on construction. Components may be subjected to immersion in diesel fuel or anti-freeze to determine compatibility with hydrocarbon fluids or engine cooling water exposure in a pump room.

The object of the evaluation is to operate the components over multiples of cycles in the presence of dirty water or air, depending on design, to accelerate possible internal or external wear in the assembly. The pre-tested components shall then be mounted to one or more diesel engines, and the operation of the accessory shall be demonstrated during full-load dynamometer operations.

#### 4.16 Variable Speed Pressure Limiting Control (VSPLC) System Cycling Tests

##### 4.16.1 Requirements

The VSPLC system shall react to pressure inputs above the system setpoint, and reduce engine RPM in order to slow the attached fire pump, and thereby, reduce the system pressure.

##### 4.16.2 Test/Verification

A test diesel engine, with attached dynamometer, shall be set up with the pre-tested accessory package mounted in the appropriate position on the speed controller/throttle. A pressure regulator and calibrated gauge, or equal, shall be used to simulate increases to sprinkler system pressure to engage the VSPLC accessory package. Engine power and RPM output shall be monitored as a function of time, electronically, or by a strip chart recorder. Response to pressure upsets shall be monitored while the engine is operating at rated power; both at the highest FM Approved rated speed, and at the lowest FM Approved rated speed. During each operational test, the pressure upset shall cause the engine to drop to the lowest operating speed allowed by the manufacturer a total of 50 times, and then return smoothly to full power. This shall simulate a minimum of one operating cycle upset during each weekly installed run, for the equivalent of a year of installed life. A “Z” factor, as described in Paragraph 3.12 shall be calculated from the data obtained for each operational test. The manufacturer shall provide data from all of the intermediate speeds to be listed.

#### 4.17 Variable Speed Pressure Limiting Control (VSPLC) System Operation Test

##### 4.17.1 Requirements

After completion of the cycling test in Section 4.16 [Variable Speed Pressure Limiting Control (VSPLC) System Cycling Tests], a diesel engine with engine driven pump and VSPLC engaged, will be operated at the highest rated speed. Speed of response to an increase in system pressure will be observed and recorded. The response time to reduce system pressure to 98 to 110 percent of set pressure shall be 5 seconds or less.

##### 4.17.2 Test/Verification

A test diesel engine shall be connected to a pump which generates a pump discharge pressure defined as follows:

$$\text{Pump Discharge Pressure} = \text{Set Pressure} \times (1 + Z)$$

using the Z factor determined in testing required in Section 4.16 [Variable Speed Pressure Limiting Control (VSPLC) System Cycling Tests]. The pump shall have a churn load less than 50 percent of the name plate power rating of the diesel engine. Regulate the suction supply to the pump such that the pump discharge pressure determined above is obtained with the VSPLC disengaged. Stop the engine. Engage the VSPLC. Re-start the engine. The time required, after the set pressure has been exceeded, to reduce the pump discharge pressure to 98 to 110 percent of set pressure shall be recorded. The response time shall be 5 seconds maximum. The engine shall run smoothly at the reduced speed. This shall be repeated for each set pressure in the VSPLC assembly supplied by the manufacturer.

#### 4.18 Additional Tests/VSPLC System

A sampling of FM Approved diesel engines shall be chosen to be witnessed by FM Approvals, if the VSPLC accessory is designed to fit multiple styles of FM Approved engines from the same manufacturer.

#### 4.19 Warning Switches

##### 4.19.1 Requirements

Low lubricant pressure and high coolant temperature warning switches shall conform to the engine manufacturer's specifications.

##### 4.19.2 Test/Verification

Warning switches shall be bench tested to simulate actual warning conditions.

#### 4.20 Battery Contactors

##### 4.20.1 Requirements

Battery contactors shall be suitable for their intended application. If FM Approved contactors are used, this test shall be waived, based upon a comparison of their FM Approved rating with the engine's full load starting current. The maximum current capacity of the main battery contactors for engines using battery starting shall be at least 200 percent of the full-load starting current requirement specified by the engine manufacturer. The cycle life of the main battery contactors shall exceed 1,000 cycles at 1.25 times the rolling current. There shall be no arcing or burning of the contacts with manual or powered actuation of the main battery contactors at the conclusion of the cycle test.

The contactor shall operate at 75 percent of rated battery voltage and shall not be damaged by a 1000V dielectric test.

##### 4.20.2 Test/Verification

The contactors shall be subjected to 30 cycles at 200 percent of full-load starting current. The cycles shall be 15 seconds on, 15 seconds off. The contactor shall then be subjected to 1000 cycles at 1.25 times the rolling current. The cycles shall be 15 seconds on, off times may be varied to eliminate overheating at the manufacturer's option. No welding or damage to the contacts shall result. The battery contactor shall be tested to ensure that it will operate at 75 percent of rated battery voltage and shall be subjected to a dielectric test at 1000V for 1 minute without damage.

#### 4.21 Electronic Control Module (ECM) Performance Test

##### 4.21.1 Requirements

The dual ECM modules and dual primary sensors will be evaluated by switching between them in combination, and attempting to start the diesel engine for each combination listed below. The diesel engine shall reach rated power at the highest rated speed for each start.

##### 4.21.2 Test/Verification

A test diesel engine with attached dynamometer, and FM Approved fire pump controller, shall be set up with each combination of ECM modules and sensors that the manufacturer is requesting for Approval. The engine shall be started each time by the fire pump controller, by simulating a loss of system pressure at the controller pressure sensing element. The engine shall reach rated power at the

highest rated speed for each combination listed below, and shall operate for five minutes at each setting. There shall be no failure to start, oscillation, or functional discrepancies between the fire pump controller and ECM diesel engine.

The ECM modules plus primary, redundant, and non-critical sensors shall be set as follows for the engine starts:

<i>Tests</i>	<i>ECM</i>	<i>Primary Sensors</i>	<i>Non-Critical Sensors</i>	<i>Redundant Sensors</i>
A	Primary On	On	Off	Off
B	Primary On	Off	Off	On
C	Alternate On	Off	Off	On
D	Alternate On	On	Off	Off
E	Alternate On	Off	On	On

**4.22 Electronic Control Module (ECM) Operation Test**

4.22.1 Requirements

The engine shall be operated at the highest rated speed and power. The sensors shall be energized and de-energized as stated in Section 4.22.2. The diesel engine shall remain at rated power at all settings. Short duration (less than 5 seconds) reductions in power are allowed, however the engine must regain rated power without operator adjustments.

4.22.2 Test/Verification

The engine shall be brought to the highest rated speed and full power. The actions stated below shall each be performed first with the primary ECM module energized and then with the alternate ECM module energized. Reset each item before proceeding to the next sensor setting. The engine shall remain at rated power for five minutes at each setting of the sensors.

- Activate the high temperature switch;
- Activate the low lubrication switch;
- Simulate failure of all non-critical sensors;
- Simulate failure of all primary sensors; and,
- Simulate failure of all redundant sensors.

**4.23 Electronic Control Module (ECM) Repeatability Test**

4.23.1 Requirements

The engine operating speed shall be adjusted by 50 rpm up or down, from the highest rated speed and full power. The engine shall return to the new adjusted engine speed after loss of battery power. This test shall be run with both the primary and alternate ECM Module.

4.23.2 Test/Verification

- a. The primary ECM shall be set on. The engine shall be brought to the highest rated test speed and full power. The engine operating speed shall be increased by 50 rpm, from the tested set point. The engine shall be stopped. Both batteries shall be disconnected for a minimum of one minute. The batteries shall be reconnected and the engine restarted. The engine shall reach full power at the adjusted speed, and operate for five minutes.

- b. The alternate ECM shall be set on. The engine shall be brought to the highest rated test speed and full power. The engine operating speed shall be decreased by 50 rpm, from the tested set point. The engine shall be stopped. Both batteries shall be disconnected for a minimum of one minute. The batteries shall be reconnected and the engine restarted. The engine shall reach full power at the adjusted speed, and operate for five minutes.

#### **4.24 ECM Indication**

##### 4.24.1 Requirement

Each engine with dual ECM modules shall have visual indication of which module is operating.

##### 4.24.2 Test/Verification

With the engine shut down, the supervisory switch circuit shall be examined and it shall be verified that the visual indicator registers the correct switch position for each ECM module.

#### **4.25 Fuel Supervisory Signal**

##### 4.25.1 Requirements

Each engine with dual ECM modules shall have a supervisory signal of low fuel pressure or fuel injection failure or, when an electric motor driven fuel pump is supplied, fuel pump failure.

##### 4.25.2 Test/Verification

With each ECM, low fuel pressure (when measured after the high pressure fuel pump) or fuel injection failure, or electric motor driven fuel pump failure, as appropriate to the system being tested, shall be simulated. It shall be verified that the supervisory signal is working properly.

#### **4.26 Reverse Power**

##### 4.26.1 Requirements

Each ECM module shall be protected from reverse power input. Failure of any sensor due to reverse power shall be deemed a failure of the protection system.

##### 4.26.2 Test/Verification

This test shall be run twice, once for the primary ECM and once for the alternate ECM module. The engine shall be set at the highest speed and full power. The engine shall be stopped with the ECM Module under test in the on position. The battery cables shall be removed from the engine and re-assembled with the opposite (incorrect) polarity and held for a minimum of 30 seconds before disconnecting the reverse power. Observe if the ECM module indicates any sign of damage. Re-assemble the battery cables with the correct polarity, and start the engine. The engine shall return to the preset conditions and shall be run for a minimum of one minute. Observe if there is any indication of sensor failure. Switch ECM modules and repeat the above tests.

#### 4.27 Controller Compatibility Testing

##### 4.27.1 Requirement

A sample ECM engine, considered representative of all submitted test samples, shall be tested in conjunction with a typical FM Approved Diesel Engine Controller, also considered representative of all FM Approved controllers, to verify compatibility of the two items when connected in accordance with the wiring in Appendix C. The two units will respond to inputs given during normal operation, and will provide appropriate signals and alarms when test signals or signal interruptions are sent from one unit to the other.

##### 4.27.2 Test/Verification

FM Approvals and the manufacturer will mutually develop a test plan for this test, based on the capabilities of the test ECM engine and the FM Approved controller when acting in concert. At minimum the test signals and alarms between engine to controller, and outputted from the controller shall be documented along with the observed responses.

#### 4.28 Additional Tests

Additional tests, including performance test of any accessories, may be required, depending on design features, results of other performance tests, material application, or to verify the integrity and reliability of the product, at the discretion of FM Approvals.

Unexplained failures shall not be permitted. A re-test shall only be acceptable at the discretion of FM Approvals with adequate technical justification of the conditions and reasons for failure.

## 5. OPERATIONS REQUIREMENTS

A quality control program is required to assure that subsequent diesel engines produced by the manufacturer at an authorized location shall present the same quality and reliability as the specific diesel engines examined. Design quality, conformance to design, and performance are the areas of primary concern. Design quality is determined during the Approval examination and tests, and is covered in the Approval Report. Conformance to design is verified by control of quality and is covered in the Facilities and Procedures Audit (F&PA). Quality of performance is determined by field performances and by periodic re-examination and testing.

### 5.1 Demonstrated Quality Control Program

5.1.1 The manufacturer shall demonstrate a quality assurance program which specifies controls for at least the following areas:

- Existence of corporate quality assurance guidelines;
- Incoming quality assurance, including testing;
- In-process quality assurance, including testing;
- Final inspection and tests;
- Equipment calibration;
- Drawing and change control;
- Packaging and shipping;
- Handling and disposition of non-conformance materials; and,

- In order to assure adequate traceability of materials and products, the manufacturer shall maintain records of all quality control tests performed, for a minimum period of two years from the date of manufacture.

#### 5.1.2 Documentation/Manual

There should be an authoritative collection of procedures and policies. Such documentation shall provide an accurate description of the quality management system while serving as a permanent reference for implementation and maintenance of that system. The system should require that sufficient records are maintained to demonstrate achievement of the required quality and verify operation of the quality system.

#### 5.1.3 Drawing and Change Control

The manufacturer shall establish a system of product configuration control that shall allow no unauthorized changes to the product. Changes to critical documents, identified in the Approval Report, must be reported to, and authorized by, FM Approvals prior to implementation for production. The manufacturer shall assign an appropriate person or group to be responsible for reporting proposed changes to FM Approved or Listed products to FM Approvals before implementation. In situations involving significant modifications to an FM Approved product, the notification shall be in the form of a formal request for an Approval examination. For modifications of a more common nature, the manufacturer shall notify FM Approvals of changes in the product or of persons responsible for keeping FM Approvals advised by means of FM Approvals Form 797, FM Approved Product Revision Report or Address/Contact Change Notice. Records of all revisions to all FM Approved products shall be maintained.

- 5.1.3.1 The table below has been included as a guide to manufacturers of what is considered to be a significant change to FM Approvals. As mentioned above, modifications that fit this category should be documented by means of a letter stating the change, and requesting a quotation for an Approval examination.

<i>Modification</i>	<i>Description/Example</i>
Increase in rated power:	The engine was originally rated at 300 hp (224 kW) and now is to be rated at 340 hp (254 kW) at a given speed.
Additional rate speeds:	The engine was originally FM Approved at speeds of 2600, 2350, 2100, and 1900 RPM, and now is to be rated at 1760 and 1470 RPM.
Additional Accessories:	The engine was originally FM Approved with turbocharger only and now is to be tested with turbocharger and aftercooler.
Addition or relocation of the manufacturing location:	The product was originally FM Approved when made in location A, and now it is desired to make in locations A and B, or in Location B only.

- 5.1.3.2 The table below has been included as a guide to modifications which may be submitted on FM Approvals Form 797.

<i>Modification</i>	<i>Description/Example</i>
Change in Company Contact Information:	Contact Name, Phone Number, FAX Number, Office Address, Company Name
Updating of Drawings:	Minor dimensional changes, or note changes, Re-creation of old drawing on CAD
Change in material or marking:	Where new material is superior, or to show proposed new marking

- 5.1.3.3 For the instances where the change is difficult to categorize, manufacturers are encouraged to contact FM Approvals and to discuss the proposed change, and the best way to transmit the request.

## 5.2 Facilities and Procedures Audit (F&PA)

- 5.2.1 An audit of the manufacturing facility is part of the Approval investigation to verify implementation of the quality control program. Its purpose is to determine that the manufacturer's equipment, procedures, and quality program are maintained to insure a consistently uniform and reliable product. Initial inspections of facilities already producing similar products may be waived at the discretion of FM Approvals.
- 5.2.2 Unannounced follow-up inspections shall be conducted at least annually by FM Approvals, or its designate, to determine continued compliance. More frequent audits may be required by FM Approvals.
- 5.2.3 The client shall manufacture the product or service only at the location(s) audited by FM Approvals and as specified in the Approval Report. FM Approvals does not permit manufacture of products bearing the FM Approvals Certification Mark at any other locations without prior written authorization by FM Approvals. A separate audit and product examination shall be required at each location.

## 5.3 Manufacturer's Responsibilities

The manufacturer shall notify FM Approvals of changes in product construction, design, components, raw materials, physical characteristics, coatings, component formulation or quality assurance procedures prior to implementation of such changes.

## 5.4 Manufacturing and Production Tests

### 5.4.1 Test Requirement No. 1 – *Performance Test*

- a. The manufacturer shall performance test 100 percent of production diesel engines in accordance with the requirements of the national or international standard(s) used during manufacturing. For ECM engines, both ECM's shall be tested. The national or international standard(s) may permit an alternate method of evaluating power, as described in Section 3.2.1.

Each engine shall be run for at least 15 minutes at full rated power and speed. An engine rated for a speed range or ranges shall be tested at both minimum and maximum speed. Engine speed and power, ambient temperature and air pressure, shall be measured, at a minimum, once per minute and recorded.

- b. The proper operation of all engine panel alarm lights as well as the fuel supervisor signals to the controller discussed in Section 4.24 (ECM Indication) should be verified by simulating faults.
- c. The power rating, based on the test data taken above and, as calculated in accordance with the method shown in Section 3.2., and the factory speed setting are to be applied to the engine nameplate at this time, along with an appropriate serial number.
- d. A fuel data plate shall be applied to the diesel engine and shall define the type and grade of fuel that the engine owner is required to supply for proper operation.

5.4.2 Test Requirements No. 2 – *VSPLC Performance Test*

- a. The manufacturer shall test 100 percent of all mechanical style VSPLC devices by conducting a hydrostatic pressure test to 1.5 times the rated working pressure for 30 seconds minimum. There shall be no evidence of leakage, cracking, or distortion.
- b. With the engine running at no-load conditions, inlet pressure shall be supplied to the VSPLC device, and the reduction in speed and “Z” rating shall be verified. The sequence of the test shall be conducted with inlet pressures at the following set points: 100 percent, 102.5 percent, 97.5 percent, 105 percent, 95 percent, 107.5 percent, 92.5 percent, 110 percent, and 90 percent, of set pressure.
- c. A VSPLC data plate shall be added to the FM Approved diesel engine listing the reduced operating speed, the “Z” factor, and the VSPLC pressure setting.

## APPENDIX A: Units of Measurement

- Barometric Pressure:** in Hg -“inches of mercury”; (kPa -“kilopascals”)  
 $kPa = 3.3864 \times \text{in Hg}$
- Brake Specific Fuel Consumption:** lb/hp·h-“pounds per horsepower hour”  
 (Kg/kW·h-“kilograms per kilowatt hour”)  
 $Kg/kW \cdot h = 0.6082 \times \text{lb/hp} \cdot h$
- Flow Rate:** gal/min -“gallons per minute”; (L/min -“liters per minute”)  
 $L/\text{min} = \text{gal}/\text{min} \times 3.785$
- Power:** hp -“horsepower”; (kW -“kilowatt”)  
 $kW = \text{hp} \times 0.7457$
- Pressure:** psi -“pounds per square inch”; (kPa -“kilopascals”)  
 $kPa = \text{psi} \times 6.895$
- Rotational Speed:** r/min -“revolutions per minute”; (same in SI Units)
- Temperature:** °F-“degrees Fahrenheit”;(C-“degrees Celsius”)  
 $^{\circ}C = (^{\circ}F - 32) \times 0.556$
- Torque:** ft·lbr -“foot pound-force”;(N·m-“Newton-meters”)  
 $N \cdot m = 0.7376 \text{ ft} \cdot \text{lbr}$   
 $kg \cdot m = 7.233 \text{ lbr} \cdot \text{ft}$

## APPENDIX B: FM Approvals Certification Marks

FM Approvals certifications marks are to be used only in conjunction with products or services that have been FM Approved by FM Approvals and in adherence with usage guidelines.



### FM APPROVED mark:

Authorized by FM Approvals as a certification mark for any product that has been FM Approved. There is no minimum size requirement for the mark, but it must be large enough to be readily identifiable. The mark should be produced in black on a light background, or in reverse on a dark background.



### FM APPROVED mark with "C" only:

Authorized by FM Approvals as a certification mark for any product that has been evaluated by FM Approvals in accordance with Canadian codes and standards. There is no minimum size requirement for the mark, but it must be large enough to be readily identifiable. The mark should be produced in black on a light background, or in reverse on a dark background.



### FM APPROVED mark with "C" and "US":

Authorized by FM Approvals as a certification mark for any product that has been evaluated by FM Approvals in accordance with US and Canadian codes and standards. There is no minimum size requirement for the mark, but it must be large enough to be readily identifiable. The mark should be produced in black on a light background, or in reverse on a dark background.

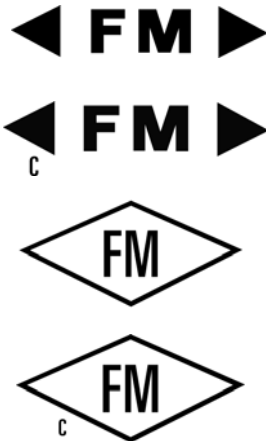

### Cast-On FM APPROVALS marks:

Where reproduction of the FM APPROVED mark described above is impossible because of production restrictions, use these modified versions of the FM APPROVED mark. There is no minimum size requirement for the mark, but it must be large enough to be readily identifiable.

*Downloadable art and other FM Approvals resources are available by visiting our Web site at [www.fmapprovals.com](http://www.fmapprovals.com)*

## USAGE GUIDELINES

- All FM Approvals certification marks are the sole property of FM Approvals LLC (“FM Approvals”) and are registered or the subject of applications for registration in the United States and many other countries. They are for use only according to these guidelines.
- FM Approvals certification marks may be used only on FM Approved products and related product packaging, in advertising material, catalogs and news releases. Use of FM Approvals certification marks on such material is not a substitute for use of the complete FM Approvals certification mark on FM Approved products and/or product packaging.
- No FM Approvals certification mark or aspect thereof may be incorporated as part of a business name, Internet domain name, or brand name/trademark for products/product lines. This includes both design aspects (the FM Approvals “diamond,” etc.) and word aspects (“FM,” “Approved,” etc.). The use of any FM Approvals certification mark as a trademark is strictly prohibited.
- The Approval Standard number or class number may not be incorporated as part of a business name, Internet domain name, or brand name/trademark for products/product lines. For example, a company may not say “ABC Company’s 4100 Fire Door is FM Approved”; the proper terminology is, “ABC Company’s Fire Door is FM Approved per Approval Standard 4100.”
- FM Approvals certification marks, except for the FM Approvals Quality System Registration mark, may not be used on business stationery/cards/signage because this could mischaracterize the relationship with FM Approvals. Additionally, these items should not reference any FM Approvals certification mark.
- Products or services may not be marketed under any mark or name similar to “FM Global,” “FM Approvals” or any of the FM Approvals certification marks. Further, products or services may not be marketed to imply a relationship beyond the scope of any Approval made by FM Approvals.
- When an FM Approvals certification mark is used in advertising material or on product packaging, all material must reflect the specific circumstances under which the product was FM Approved. The material must clearly differentiate between products that are FM Approved and those that are not, and may not, in any way, imply a more substantial relationship with FM Approvals.
- A company may not reference the intent to submit a product for Approval or the expectation that a company will have a certain product FM Approved in the future. For example, a company may not state, “Approval by FM Approvals pending” or “Approval by FM Approvals applied for.”
- FM Approvals certification marks should not be preceded or followed by a qualifier that indicates a degree of certification or acceptability. For example, “exceeds,” “first” or “only” may not be used to qualify any FM Approvals certification mark.
- Only original artwork issued by FM Approvals should be used. The FM Approvals certification marks should not be altered in any way other than to resize the artwork proportionately. Unacceptable uses of the marks include, but are not limited to, adding/deleting wording or artwork, reducing the artwork to an illegible size, animation or distortion.
- The text of the FM Approvals certification marks may not be translated into any language other than English.
- FM Approvals certification marks must appear in a size and location that is readily identifiable, but less prominent than the name of the owner of the certification or the manufacturer/seller/distributor of the certified products.

APPENDIX C: Figure

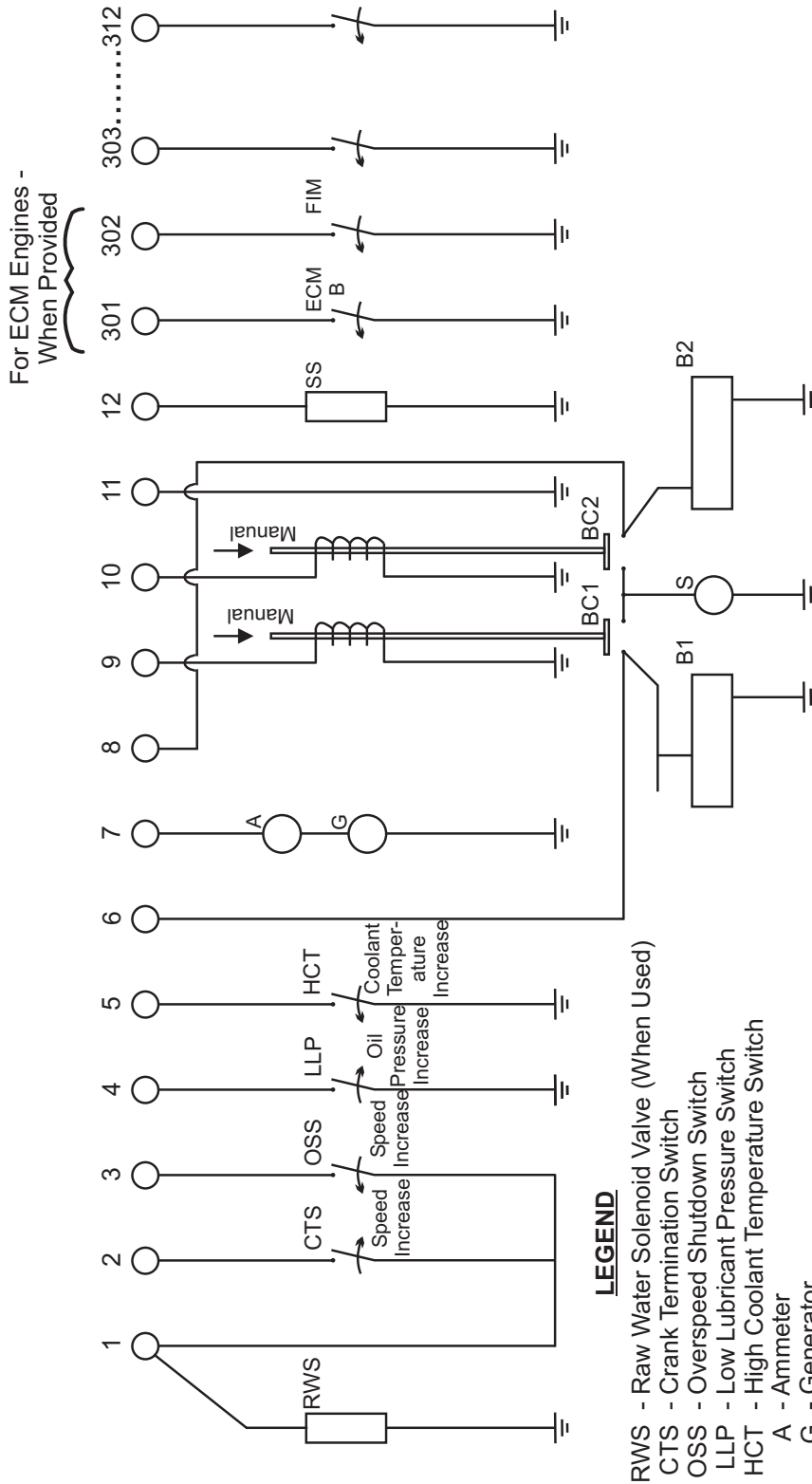

For ECM Engines -  
When Provided

**LEGEND**

- RWS - Raw Water Solenoid Valve (When Used)
- CTS - Crank Termination Switch
- OSS - Overspeed Shutdown Switch
- LLP - Low Lubricant Pressure Switch
- HCT - High Coolant Temperature Switch
- A - Ammeter
- G - Generator
- BC1 - Main Battery Contactor 1
- BC2 - Main Battery Contactor 2
- B1 - Battery 1
- B2 - Battery 2
- S - Starter
- SS - Shut down Solenoid (Sometimes Wired Directly to OSS)
- ECM B - ECM selector switch is in alternate ECM position
- FIM - Fuel injection malfunction

**NOTE:** Terminals 301 through 312 shall be electrically isolated from the ECM (Electronic Control Module).

## APPENDIX D: Sample Listing

Standard Diesel Engine Listing

**ABC Company, 123 Wood Street, City, State Zip Code**

<i>Product Designation</i>	<i>Rated Power</i>		<i>Rated Speed</i>
	<i>hp</i>	<i>(kW)</i>	<i>r/min</i>
ABCD-01XZ	350	(260)	1470
	425	(315)	1760
	460	(345)	1900
	500	(375)	2100
	525	(390)	2350
For rated power at intermediate speeds, refer to ABC Dwg. No. ABCD-1234-01 dated 04/01/96			

Standard Diesel Engine with VSPLC Option Listing

**ABC Company, 123 Wood Street, City, State Zip Code**

<i>Product Designation</i>	<i>Rated Power</i>		<i>Rated Speed</i>	<i>“Z” Factor</i>
	<i>hp</i>	<i>(kW)</i>	<i>r/min</i>	
ABCDEF-Z	40	(30)	1470	0.40
	50	(35)	1760	0.55
	55	(40)	2100	0.70
For rated power at intermediate speeds, refer to ABC Dwg. No. ABCD-4321-01 dated 05/15/98				

## APPENDIX E: Tolerances

Unless otherwise stated, the following tolerances shall apply:

Amps	$\pm 0.25$ percent of value
Brake Specific Fuel Consumption	$\pm 1$ percent of value
Length	$\pm 2$ percent of value
Power	$\pm 1$ percent of value
Pressure	within $+ 5/- 0$ psi of value
Speed	$\pm 10$ rpm
Temperature	$\pm 5$ °F ( $\pm 3$ °C)
Time	$+ 5/-0$ seconds $+ 0.1/-0$ minutes $+ 0.1/-0$ hours $+ 0.25/-0$ days
Volts	$\pm 1$ volts of value
Volume	$\pm 5$ percent of value

Unless stated otherwise, all tests other than operating tests shall be carried out at a room (ambient) temperature of  $68$  °F  $\pm 9$  °F ( $20$  °C  $\pm 5$  °C).



*Member of the FM Global Group*

Printed in USA