



Member of the FM Global Group

Approval Standard for Indicating Valves (Butterfly or Ball Type)

Class Number 1112

August 2006

Foreword

The FM Approvals certification mark is intended to verify that the products and services described will meet FM Approvals' stated conditions of performance, safety and quality useful to the ends of property conservation. The purpose of Approval Standards is to present the criteria for FM Approval of various types of products and services, as guidance for FM Approvals personnel, manufacturers, users and authorities having jurisdiction.

Products submitted for certification by FM Approvals shall demonstrate that they meet the intent of the Approval Standard, and that quality control in manufacturing shall ensure a consistently uniform and reliable product. Approval Standards strive to be performance-oriented. They are intended to facilitate technological development.

For examining equipment, materials and services, Approval Standards:

- a) must be useful to the ends of property conservation by preventing, limiting or not causing damage under the conditions stated by the Approval listing; and
- b) must be readily identifiable.

Continuance of Approval and listing depends on compliance with the Approval Agreement, satisfactory performance in the field, on successful re-examinations of equipment, materials, and services as appropriate, and on periodic follow-up audits of the manufacturing facility.

FM Approvals LLC reserves the right in its sole judgment to change or revise its standards, criteria, methods, or procedures.

TABLE OF CONTENTS

1. INTRODUCTION	1
1.1 Purpose	1
1.2 Scope	1
1.3 Basis for Requirements.....	1
1.4 Basis for Approval.....	2
1.5 Basis for Continued Approval	2
1.6 Effective Date	2
1.7 System of Units	2
1.8 Applicable Documents	3
1.9 Definitions	3
2. GENERAL INFORMATION.....	5
2.1 Product Information.....	5
2.2 Approval Application Requirements	5
2.3 Requirements for Samples for Examination.....	6
3. GENERAL REQUIREMENTS.....	6
3.1 Review of Documentation	6
3.2 Physical or Structural Features - Valve	6
3.3 Physical or Structural Features - Gear Operator	7
3.4 Markings.....	7
3.5 Manufacturer's Installation and Operation Instructions.....	8
3.6 Materials	8
3.7 Calibration	8
4. PERFORMANCE REQUIREMENTS.....	9
4.1 Examination.....	9
4.2 Ball or Disc Strength	9
4.3 Seat Leakage.....	9
4.4 Stem Seal	10
4.5 Hydrostatic Strength.....	10
4.6 Valve Assembly Strength	10
Figure 4.6.2 - Valve Operator Strength.....	11
4.7 Ultimate Operator Torque.....	11
4.8 Durability Test.....	12
Table 4.8.1. Operating Torques Required to Open.....	12
Table 4.8.2. Durability Flow Rates, 10 ft/sec (3.0 m/sec).....	13
4.9 Close Quarters Durability Test - Butterfly Type	13
Table 4.9.1A Dimensions for Grooved Elbow Connections	14
Table 4.9.1B Dimensions for Threaded Elbows	14
Figure 4.9.2 Close Quarter Durability Orientations	14
4.10 Friction Loss Determination	15
Table 4.10.2. - Friction Loss Flows, 20 ft/sec (6.1 m/sec)	15
4.11 Visibility.....	15
4.12 Orientation.....	16
4.13 Handwheel or Crank Strength	16
Figure 4.13.2 - Handwheel or Crank Strength	16
4.14 Water Hammer	17
4.15 Indicator Strength.....	17
4.16 Water Absorption Test - Resilient Seated Valves Only.....	17
4.17 Aging Test	18
4.18 Corrosion Protection Coating	18

4.19	Submerged Service	18
4.20	Supervisory Switches - Activation.....	19
4.21	Supervisory Switches - Cyclic	19
4.22	Supervisory Switches - Environmental.....	19
	Table 4.22.2a Indoor Service Only.....	19
	Table 4.22.2b Indoor and Outdoor Service	20
4.23	Supervisory Switches - Outdoor Service	20
4.24	Supervisory Switches - Dielectric.....	20
	Table 4.24.2 Dielectric Test	20
4.25	Supervisory Switches - Vibration	21
4.26	Supervisory Switches - Strain Relief	21
4.27	Supervisory Switches - Bonding Resistance.....	21
4.28	Additional Tests.....	21
5.	OPERATIONS REQUIREMENTS	22
5.1	Demonstrated Quality Control Program	22
5.2	Facilities and Procedures Audit (F&PA)	24
5.3	Manufacturer's Responsibilities	24
5.4	Manufacturing and Production Tests	24
	5.4.1 Test Requirement No. 1 - Seat Leakage Test.....	24
	5.4.2 Test Requirement No. 2 - Hydrostatic Test	24
	5.4.3 Test Requirement No. 3 - Operation Test.....	24
APPENDIX A: Units of Measurement		25
APPENDIX B: FM Approvals Certification Marks		26
APPENDIX C: Sample Listing		28
APPENDIX D: Durability Test Adapter.....		29
APPENDIX E: Tolerances.....		30

1. INTRODUCTION

1.1 Purpose

- 1.1.1 This standard states Approval criteria for manually operated indicating valves that control the water supply to a fire protection system.
- 1.1.2 Approval criteria include, but are not limited to, performance requirements, marking requirements, examination of manufacturing facility(ies), audit of quality assurance procedures, and a follow-up program.

1.2 Scope

- 1.2.1 This standard encompasses the design and performance requirements for indicating valves for their intended application of long term water flow control. Indicating valves are usually installed above ground and indoors. They are constructed so that an informed observer can visually determine the position of the valve ball or disc indicating if the valve is open or closed.
- 1.2.2 This standard encompasses the design and performance requirements for indicating valves in the following sizes: 1, 1-1/4, 1-1/2, 2, 2-1/2, 3, 4, 5, 6, 8, 10 and 12 in. nominal pipe sizes (NPS) and equivalent metric sizes. Other sizes will be evaluated on a case-by-case basis.
- 1.2.3 This standard defines the requirements for indicating valves in either butterfly or ball valve configurations. Typical end connections for butterfly valves are: grooved end, lug style, wafer style, flanged or threaded. Typical end connections for ball valves are: grooved end and threaded. Other styles of end connection shall be evaluated on a case-by-case basis.
- 1.2.4 Approval Standards are intended to verify that the product described will meet stated conditions of performance, safety, and quality useful to the ends of property conservation.

1.3 Basis for Requirements

- 1.3.1 The requirements of this standard are based on experience, research and testing, and/or the standards of other organizations. The advice of manufacturers, users, trade associations, jurisdictions and/or loss control specialists was also considered.
- 1.3.2 The requirements of this standard reflect tests and practices used to examine characteristics of indicating valves for the purpose of obtaining Approval. Indicating valves having characteristics not anticipated by this standard may be FM Approved if performance equal, or superior, to that required by this standard is demonstrated, or if the intent of the standard is met. Alternatively, indicating valves which meet all of the requirements identified in this standard may not be FM Approved if other conditions which adversely affect performance exist or if the intent of this standard is not met.

1.4 Basis for Approval

Approval is based upon satisfactory evaluation of the product and the manufacturer in the following major areas:

1.4.1 Examination and tests on production samples shall be performed to evaluate:

- The suitability of the product;
- The performance of the product as specified by the manufacturer and required by FM Approvals; and as far as practical,
- The durability and reliability of the product.

1.4.2 An initial facilities and procedures audit shall be conducted to evaluate the manufacturer's ability to consistently produce the product which was examined and tested as part of the Approval project. The audit will review the facility and in-place quality control procedures used in the manufacturing of the product. Typically areas of review are: incoming inspection, work in progress, production testing, final quality control, marking, calibration of equipment, shipping procedures and drawing control. These examinations are repeated periodically as part of the FM Approvals' product follow-up program, (Refer to Section 5.2, Facilities and Procedures Audits).

1.5 Basis for Continued Approval

1.5.1 Continued Approval is based upon:

- Production or availability of the product as currently FM Approved;
- The continued use of acceptable quality assurance procedures;
- Satisfactory field experience;
- Compliance with the terms stipulated in the Master Agreement; or Approval Agreement;
- Satisfactory re-examination of production samples for continued conformity to requirements; and,
- Satisfactory Facilities and Procedures Audits (F&PAs) conducted as part of the FM Approvals' product follow-up program.

1.5.2 Also, as a condition of retaining Approval, manufacturers may not change an FM Approved product or service without prior authorization by FM Approvals, (Refer to Section 5.1.3 Drawing and Change Control).

1.6 Effective Date

The effective date of an Approval standard mandates that all products tested for Approval after the effective date shall satisfy the requirements of that standard. Products FM Approved under a previous edition shall comply with the new version by the effective date or forfeit Approval.

The effective date of this standard is **July 31, 2008** for compliance with all requirements.

1.7 System of Units

Units of measurement used in this standard are United States (U.S.) customary units. These are followed by their arithmetic equivalents in International System (SI) units, enclosed in parentheses. The first value stated shall be regarded as the requirement. The converted equivalent value may be approximate. Appendix A lists the selected units and conversions to SI units for measures appearing in this standard. Conversion of U.S. customary units is in accordance with the Institute of Electrical and Electronics Engineers (IEEE)/American Society for Testing and Materials (ASTM) SI 10-2002, *American National Standard for Use of the*

International System of Units (SI): The Modern Metric System. One unit of measurement (liters), outside of, but recognized by SI, is commonly used in international fire protection and is used in this standard.

1.8 Applicable Documents

The latest versions of the following standards, test methods, and practices are referenced in this standard:

- IEEE/ASTM SI 10-2002, *American National Standard for Use of the International System of Units (SI): The Modern Metric System*
- ANSI/American Society of Mechanical Engineers (ASME) B16.3 - 1998, *Malleable Iron Threaded Fittings*
- ANSI/ASME B16.5 - 1988, *Pipe Flanges and Flanged Fittings*
- ASME/ANSI B1.20.1 - 2001, *Pipe Threads, General Purpose (Inch) Revision and Redesignation of ASME/ANSI B2.1-1968 R(2001)*
- ASME B36.10M - 2000, *Welded and Seamless Wrought Steel Pipe*
- ASTM D471 - 1997, *Standard Test Method for Rubber Property - Effect of Liquids*
- ASTM D572 - 1988 (Re-approved 1994), *Standard Test Method for Rubber - Deterioration by Heat and Oxygen*
- ASTM D2444 - 1999, *Standard Test Method for Determination of the Impact Resistance of Thermoplastic Pipe and Fittings By Means of A Tup (Falling Weight)*
- American Water Works Association (AWWA) C606-2004, *Joints, Grooved and Shouldered Type Approval Standard Class 3810 - March 1989, Electrical and Electronic Test, Measuring, and Process control Equipment*
- FM Global Property Loss Prevention Data Sheets
- National Electrical Manufacturers Association (NEMA) Standards Publication 250-1997, *Enclosures for Electrical Equipment (1000 Volts Maximum)*
- National Fire Protection Association (NFPA) 72®, *National Fire Alarm Code® 2002 Edition*

1.9 Definitions

For purposes of this standard, the following terms apply:

Accepted

This term refers to installations acceptable to the authority enforcing the applicable installation rules. When the authority is FM Global, such locations are termed “FM Global Accepted.” Acceptance is based upon an overall evaluation of the installation. Factors other than the use of FM Approved equipment impact upon the decision to accept, or not to accept. Acceptance is not a characteristic of a product. It is installation specific. A product accepted for one installation may not be acceptable elsewhere. (Contrast with FM Approved.)

Corrosion Resistant

Having resistance to corrosion equal to or exceeding that of bronze alloy having a minimum copper content of 80 percent, or constructed of 300 or 400 Series Stainless Steel.

Flanged End Valves

Valves having flanged ends per the dimensional values shown in ANSI/ASME B16.5, *Pipe Flanges and Flanged Fittings*, as a default. Flanges to other national or international standards shall be evaluated on a case-by-case basis.

FM Approved Mark

The FM Approved Mark is detailed in Appendix B. Its use is mandatory on all units of FM Approved indicating valves. These registered marks cannot be used except as authorized by FM Approvals via the granting of Approval to a specific product.

FM Approved

This term refers to products FM Approved by FM Approvals. Such products are listed in the Approval Guide, a publication of FM Approvals, issued annually, or one of the supplements. All products so listed have been successfully examined by FM Approvals, and their manufacturers have signed and returned a Master Agreement to FM Approvals. These forms obligate the manufacturer to allow re-examination of the product and audit of facilities and procedures at FM Approvals discretion. It further requires the manufacturer not to deviate from the as-FM Approved configuration of the product without review by and agreement of FM Approvals. Approval is product specific.

Grooved End Valves

A grooved end valve is characterized by having grooved ends cast or subsequently machined on the inlet and outlets of the valve body; such that the valve may be installed in the sprinkler system piping using FM Approved grooved end couplings. Manufacturers are allowed to define their own dimensional values in order to achieve higher performance for the assembled joint. However, most grooved end connections follow the dimensional values shown in AWWA C606, *Joints, Grooved and Shouldered Type*, for IPS Pipe.

Indicating Valve

An indicating valve is a valve that indicates orientation of the ball or disc by visual observation. The position of the valve ball or disc may also be monitored by the use of supervisory switches.

Lug Style Valves

This valve type refers to a butterfly valve design wherein tapped holes are machined into “lugs” found around the circumference of the valve body. This allows for flange bolting to connect to each side of the valve during installation in the sprinkler system piping. For the purposes of this standard, lug style valves shall comply with the dimensional values shown in ANSI/ASME B16.5, *Pipe Flanges and Flanged Fittings*. Lug style valves manufactured to other national or international standards shall be evaluated on a case-by-case basis.

Maximum Operating Torque

The maximum torque required to either open or close a valve. The opening maximum operating torque is the maximum torque, measured at the handwheel shaft, necessary to translate a closed valve (against the valve stops) to the full open position. While closed, the valve will be subjected to an upstream pressure equal to the rated working pressure. The closing maximum operating torque is the maximum torque necessary to translate a full open valve to the full closed position. The torque shall be measured as the valve is closed against the flow rate developed by a fluid velocity of 20 ft/sec (6.1 m/sec) in Schedule 40 steel pipe.

Rated Working Pressure

This is the maximum sustained pressure at or below which the valve shall operate trouble free. This also sets the basis for the testing described in Section 4, Performance Requirements.

Schedule 40 Steel Pipe

For the purposes of this Approval Standard, references have been made to “Schedule 40” steel sprinkler pipe. In all cases, the reference is made to the pipe dimensions outlined in ASME B36.10, *Welded and Seamless Wrought Steel Pipe*. It is important to note that other national or international standards also make reference to “Schedule 40” pipe but may in fact have different dimensions for the same nominal pipe size.

Threaded End Valves

A threaded end valve is characterized by having threads machined into the valve body and endplate such that the valve may be installed in a threaded pipe system. For the purposes of this standard, threaded end refers to ASME/ANSI B1.20.1, *Pipe Threads, General Purpose (Inch) Revision and Redesignation of ASME/ANSI B2.1-1968 R(2001)*, for tapered pipe threads. Other thread forms may be acceptable on a case-by-case basis.

Ultimate Operator Torque (UOT)

The ultimate operator torque (UOT) is defined as the input torque applied to the operator handwheel or crank, with the disc or ball blocked in the open position that causes a component inside the gear operator to fail.

Wafer Style Valves

This valve type refers to a butterfly valve design wherein the valve is placed between two pipe flanges and held in place by the flange bolting. In this style of valve, the flange bolts surround the valve but do not connect to the valve directly.

2. GENERAL INFORMATION

2.1 Product Information

- 2.1.1 These valves usually have six major components: a body, valve operator, drive shaft, resilient or metal seat, disc or ball, and visual indicator.
- 2.1.2 The valve operator is a gear box mechanism that is mounted on top of the valve body. A handwheel or crank provides the input torque to the operator that rotates the disc or ball through the valve drive shaft. The gear box provides a torque multiplier ratio, such that the output torque to the disc is several multiples of the input (handwheel or crank) torque. This ratio also results in an incremental turn of the valve element for every full turn of the handwheel or crank. This prevents closing the disc or ball rapidly, and therefore precludes water hammer.
- 2.1.3 The disc or ball is mounted in the waterway of the valve body and controls waterflow when it is rotated between 0° and 90° (fully opened to fully closed).
- 2.1.4 The indicator is the top most component of the valve operator and is assembled directly to the drive shaft. It shows the position of the disc or ball in the waterway at all times, even after the determination of the Ultimate Operator Torque.
- 2.1.5 In order to meet the intent of this standard, indicating valves must be examined on a model-by-model, type-by-type, manufacturer-by-manufacturer, and plant-by-plant basis. This is predicated on the basis that identical designs, fabricated in identical materials by different manufacturers or, even by different plants of the same manufacturer, have been seen to perform differently in testing. Sample indicating valves, selected in conformance to this criterion, shall satisfy all of the requirements of this standard.

2.2 Approval Application Requirements

- 2.2.1 To apply for an Approval examination the manufacturer, or its authorized representative, should submit a request to:

Hydraulics Group Manager
FM ApprovalsSM
Hydraulics Laboratory
Member of the FM Global Group
743A Reynolds Road
West Glocester, RI 02814 U.S.A.

2.2.2 The manufacturer shall provide, at a minimum, the following preliminary information with any request for Approval consideration:

- A complete list of all models, types, sizes, and options for the products or services being submitted for Approval consideration;
- General assembly drawings, one complete set of manufacturing drawings, materials list(s) and physical property specifications, anticipated marking format, brochures, sales literature, specification sheets, installation, operation and maintenance procedures; and,
- The number and location of manufacturing facilities.

2.2.3 All documents shall be controlled by the manufacturer's Quality Assurance procedures and shall identify the manufacturer's name, document number or other form of reference, title, date of last revision, and revision level. All foreign language documents shall be provided with English translation.

2.3 Requirements for Samples for Examination

Following set-up and authorization of an Approval examination, the manufacturer shall prepare samples for examination and testing. Sample requirements are to be determined by FM Approvals following review of the preliminary information. Sample requirements may vary depending on design features, results of prior testing, and results of the foregoing tests. It is the manufacturer's responsibility to submit samples representative of production. Any decision to use data generated utilizing prototypes is at the discretion of FM Approvals.

3. GENERAL REQUIREMENTS

3.1 Review of Documentation

During the initial investigation and prior to physical testing, the manufacturer's specifications, technical data sheets, and design details shall be reviewed to assess the ease and practicality of installation and use. The product shall be capable of being used within the limits of the Approval investigation.

3.2 Physical or Structural Features - Valve

3.2.1 Indicating valves shall be designed for a minimum rated working pressure of 175 psi (1205 kPa).

3.2.2 Indicating valves shall have wafer, lug, flanged, grooved or threaded end connections. Other types of end connections shall be evaluated on a case-by-case basis.

3.2.3 The indicating valve shall provide either a single or double waterway when it is in the wide open position. The total area of this waterway shall not be less than 60 percent of the internal cross-sectional area of the connecting pipe.

3.2.4 The disc or ball assembly and disc or ball shaft shall be capable of withstanding a torque applied to the handwheel or crank of at least three times the torque required to open the valve against a hydrostatic pressure differential equal to the rated working pressure.

3.2.5 The valve shall have a stem seal which prevents water within the body from escaping to atmosphere.

- 3.2.6 Valves submitted for testing shall be true production samples and shall be free of sharp edges, burrs or other imperfections liable to injure the installer or interfere with proper assembly of the unit.

3.3 Physical or Structural Features - Gear Operator

- 3.3.1 It shall be possible to lock or chain the valve or operator so that the valve disc or ball cannot be moved from the fully open position without use of bolt cutters. A chain or cable and padlock are an acceptable locking method. Once locked, the valve shall not travel more than 5 percent of its full travel.
- 3.3.2 The valve operator, and associated body and operator support components, shall be capable of withstanding a torque applied to the handwheel or crank of at least three times the torque required to open the valve against a hydrostatic pressure differential equal to the rated working pressure.
- 3.3.3 If rotary motion is employed to operate the valve, the direction to open shall be counterclockwise.
- 3.3.4 Stops shall be provided to ensure that the disc or ball is properly positioned in the waterway at fully open and closed positions. Externally adjustable stops are acceptable.
- 3.3.5 The handwheel or crank shall be pinned or permanently assembled to the operator drive shaft.
- 3.3.6 The indicator flag shall indicate the position of the disc/ball at all times, (See Section 4.7.1).
- 3.3.7 Valves submitted for evaluation with supervisory switches shall have a wiring diagram and electrical voltage/ampere requirements labeled on the operator cover. The markings shall be cast or provided on a permanently-marked, legible, corrosion-resistant nameplate, permanently fastened to the operator cover. Alternative markings shall be reviewed on a case-by-case basis.
- 3.3.8 Indicating valves submitted for outdoor service shall be equipped with an enclosure that is resistant to incidental contact with the enclosed equipment, rain, external icing, and dust. The enclosure gaskets shall not be damaged when the enclosure is opened for servicing as needed.

3.4 Markings

- 3.4.1 The following minimum information shall be in cast characters on the valve and/or shown on a permanently-marked, legible, corrosion-resistant nameplate, permanently fastened to the valve. External adhesive labels are not permitted for use as valve markings.
- Manufacturer's name or trademark;
 - Valve size;
 - Manufacturers date code, (i.e. mm/yy);
 - Rated working pressure;
 - Model designation;
 - FM Approved Mark, (see Appendix B);
 - Manufacturing source code where necessary; and
 - Valves with supervisory switches shall have a wiring diagram and electrical voltage/ampere requirements labeled on the operator cover. (Please refer to Section 3.3.7 for more information on this requirement.)
- 3.4.2 The words "OPEN" and "CLOSED" (or "SHUT") shall be in cast letters or stamped on the cover of the valve operator. The indicator shall point to these words when the valve is fully open or closed. Raised arrowheads or similar symbols may be placed near these words to show more precisely the extreme positions of the valve.

- 3.4.3 An arrow showing the direction of opening shall be cast on the assembly, marked in a fixed nameplate, or stamped on the handle or handwheel. All letters and symbols shall be large enough to be easily read by a person standing 3 ft (0.9 m) from the valve.
- 3.4.4 The model or type identification shall correspond with the manufacturer's catalog designation and shall uniquely identify the product as FM Approved. The manufacturer shall not place this model or type identification on any other product unless covered by a separate agreement.
- 3.4.5 The FM Approved Mark (see Appendix B) shall be displayed visibly and permanently on the product. The manufacturer shall not use this mark on any other product unless such product is covered by separate Approval Report with FM Approvals.
- 3.4.6 All markings shall be legible and durable.

3.5 Manufacturer's Installation and Operation Instructions

- 3.5.1 Maintenance, operation and installation instructions, including any special dimensional requirements, shall be furnished by the manufacturer with each valve.
- 3.5.2 The instruction manual shall outline in detail the field procedures for repairing the valve assembly. It shall conspicuously include the statement:

“ALL REPLACEMENT PARTS MUST BE OBTAINED FROM THE MANUFACTURER TO ASSURE PROPER OPERATION OF THE VALVE, AND TO MAINTAIN APPROVAL OF THE DEVICE.”

The manual shall be reviewed for completeness and ease of comprehension.

3.6 Materials

All materials used in these indicating valves shall be suitable for the intended application. Particular consideration shall be given to the corrosion resistance of the materials used for the ball or disc, the stem, bushings and seals. Gear operator housings shall be made from materials with melting points greater than 1470 °F (800 °C) are not acceptable. Alternative materials may be considered, provided they meet the intended performance requirements. When unusual materials are used, special tests may be necessary to verify their suitability. All components shall withstand the normal abuse of shipping, handling and installation.

3.7 Calibration

All equipment used to verify the test parameters shall be calibrated within an interval determined on the basis of stability, purpose, and usage of the equipment. For testing conducted at locations other than FM Approvals, a copy of the calibration certificate for each piece of test equipment is required for FM Approvals' records that indicate that the calibration was performed to standards traceable to the National Institute of Standards and Technology (NIST) or to other acceptable reference standards by an accredited ISO 17025 calibration laboratory. The test equipment must be clearly identified by label or sticker showing the last date of the calibration and the next due date. In addition, a copy of the ISO 17025 accreditation certificate for the calibration laboratory is required for FM Approvals records.

The calibration of recently purchased new equipment is also required. Documentation indicating either the date of purchase or date of shipment, equipment description, model and serial number is required for identification. The period from the time the equipment was put into service to the date of testing must be within an interval that does not require the equipment to be calibrated as determined on the basis of the parameters mentioned above.

4. PERFORMANCE REQUIREMENTS

4.1 Examination

4.1.1 Requirement

The indicating valve(s) shall conform to the manufacturer's drawings and specifications and to FM Approvals requirements.

4.1.2 Test/Verification

Sample valves shall be examined and compared to drawings and specifications. It shall be verified that the samples conform to the physical and structural requirements described in Section 3, General Requirements.

4.2 Ball or Disc Strength

4.2.1 Requirement

The valve ball or disc shall be able to withstand exposure to hydrostatic pressure of two times the rated working pressure for five minutes without functional impairment. During and at the conclusion of the test, no fracture, permanent distortion, or functional impairment shall occur. After this test the valve shall be fully operable and shall comply with the leakage requirements in Section 4.3 (Seat Leakage).

4.2.2 Tests/Verification

A sample valve of each size shall be closed. With one side open to atmosphere, the other side shall be hydrostatically pressurized to two times the rated working pressure. The test pressure shall be held for five minutes. For this strength test leakage past the seat is allowed. The test pressure must be maintained for the duration of the test. This test shall be repeated for both directions of flow.

4.3 Seat Leakage

4.3.1 Requirement

This test shall be conducted after the Ball/Disc Strength test, (Section 4.2). For metal to metal seated indicating valves; leakage shall not exceed one fluid ounce per hour (30 cm³/h) at or below the rated working pressure, and shall not exceed one fluid ounce per hour per inch (30 cm³/h/25.4 mm) of nominal valve size at 125 percent of the rated working pressure. Resilient seated indicating valves shall not leak.

4.3.2 Test/Verification

With one side open to atmosphere, the other side of each size valve shall be hydrostatically tested at 100 percent of the rated working pressure and 125 percent of the rated working pressure. The test shall be conducted for a duration of five minutes at each pressure. Leakage, if any, shall be measured and compared to allowed limits based on the seat type.

4.4 Stem Seal

4.4.1 Requirement

Stem seals shall not leak when subjected to a hydrostatic pressure equal to the rated working pressure.

4.4.2 Tests/Verification

A sample valve of each size with the ball or disc in a partially open position shall be subjected to its rated working pressure for five minutes with no visible stem leakage. Cycling of the ball or disc six times during this time span shall not cause leakage past the stem seal.

4.5 Hydrostatic Strength

4.5.1 Requirement

Valve bodies shall withstand a hydrostatic pressure of four times the rated working pressure without rupture, cracking or permanent distortion.

4.5.2 Test/Verification

With the ball or disc in the partially open position, valve bodies of each valve size shall be subjected to a hydrostatic pressure of 700 psi (4825 kPa) or four times the rated working pressure, whichever is greater, for a duration of five minutes. There shall be no visible rupture, cracking, or permanent distortion to the valve body as a result of this test.

4.6 Valve Assembly Strength

4.6.1 Requirement

The indicating valve shall be capable of withstanding an input torque of at least three times the maximum operating torque, applied to the handwheel or crank, required to operate the valve against a flow developed by a line velocity of 20 ft/sec (6.1 m/sec) when open, and rated working pressure when closed. The maximum value for operating torque values shall not exceed those developed by an 80 lb (36.3 kg) tangential force applied to the grip surface of the handwheel or crank in the direction of rotation. At the conclusion of this test, the valve shall function properly from the fully open to the fully closed position, and shall meet the seat leakage requirements as described in Section 4.3, Seat Leakage.

4.6.2 Tests/Verification

4.6.2.1 Tests shall be conducted to determine the maximum operating torque, applied to the valve handwheel, required to open and close the valve against a flow developed by a line velocity of 20 ft/sec (6.1 m/sec) when open, and rated working pressure when closed. These torque readings may be obtained during Close Quarters Durability testing, (Section 4.9) or Friction Loss Determination testing (Section 4.10) as the test set-ups are identical. If the manufacturer has already generated these values, spot checks shall be made to verify the submitted data. The maximum operating torque shall not exceed those developed by an 80 lb (36.3 kg) tangential force applied to the grip surface of the handwheel or crank in the direction of rotation.

- 4.6.2.2 An input torque shall be applied to the valve operator while the disc or ball is held in the open position. This input torque shall be three times the maximum test value as determined in Section 4.6.2.1. The disc or ball shall be blocked open using a material that minimizes the chance of damage to the sealing surfaces during this test. After the input torque is released, the valve shall be capable of its full range travel without sticking, binding, etc.

Figure 4.6.2 - Valve Operator Strength

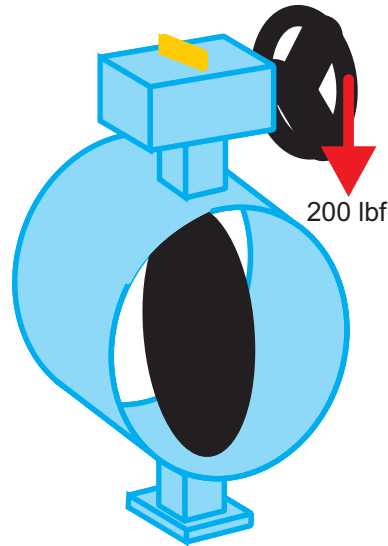

- 4.6.2.3 A 200 lb (91 kg) tangential force shall be applied to the handwheel or crank in such a manner as to stress the open and closed stops within the operating mechanisms without ensuing damage (See Figure 4.6.2). After the 200 lb (91 kg) tangential force has been released, the valve shall be capable of its full range of travel without sticking, binding, etc.
- 4.6.2.4 After the tests in Section 4.6.2.2 and 4.6.2.3 have been completed, the valve shall meet the seat leakage requirements as described in Section 4.3, Seat Leakage. The valve and operator assembly shall not be damaged as a result of this test.

4.7 Ultimate Operator Torque

4.7.1 Requirement

The Ultimate Operator Torque shall be determined by blocking the disc or ball in the partially open position and applying an increasing input torque to the handwheel until there is a failure of a gear operator component. The failed component shall be located within the operator housing so that a protective cover must be removed to replace it. The failure component shall not disturb the relationship between the position of the disc or ball and the indicator flag at any time.

- It shall not be necessary to remove the valve from the sprinkler system piping to replace the failed gear operator component.
- In the event of failure of the gear operator component, it shall be possible to manually open and/or close the valve using tools of the trade, but only after removing the operator cover.
- The disc/ball shaft shall not be able to be ejected due to the forces caused by the valve's rated working pressure during replacement of the failed gear operator component.

4.7.2 Tests/Verification

With the valve disc or ball blocked in the partially open position, the input torque applied to the valve operator shall be increased until there is a failure of a component of the gear operator.

Method of Determining Ultimate Operator Torque

- 4.7.2.1 Block the disc or ball in a partially open position. The failure of the gear operator component shall not disturb the relationship between the position of the disc or ball and the indicator flag.
- 4.7.2.2 Apply a torque directly to the handwheel (crank) or input shaft of the operator. If an exterior section of weakness [such as the pinning of the handwheel (crank) to the shaft] is incorporated in the design in order to satisfy the requirements of other approval agencies, the exterior section of weakness may be bypassed.
- 4.7.2.3 Using a torque wrench, turn the handwheel shaft until there is no longer an increase or until there is a decrease or sudden drop of the torque value observed on the dial of the torque wrench. The maximum torque value observed on the torque wrench dial is considered the Ultimate Operator Torque. At that point, determine if a component within the gear operator has either failed or the yield strength of the material has been exceeded. If failure cannot be detected, continue until failure can be detected.

4.8 Durability Test

4.8.1 Requirement

Each size of indicating valve shall be capable of 1000 full cycles opening against the rated working pressure, and closing against the flow developed by a line velocity of 10 ft/sec (3.0 m/sec). After the completion of the cycling test, the valve shall be fully operable and shall comply with the seat leakage requirements in Section 4.3 (Seat Leakage) and the stem seal requirements in Section 4.4 (Stem Seal). At the conclusion of 1000 cycles the operating torque required to open the valve against a hydrostatic pressure differential equal to the rated working pressure, shall not exceed the values in the Table 4.8.1 as a result of this test.

Table 4.8.1. Operating Torques Required to Open

<i>Pre-Durability Testing Initial Torque</i>		<i>Post Test Allowable Variation</i>	
<i>lbf:ft</i>	<i>(N·m)</i>	<i>lbf:ft</i>	<i>N·m</i>
10 and under	(13 and under)	± 2	(± 2.7)
11 through 20	(14 through 27)	± 3	(± 4.1)
21 through 50	(28 through 68)	± 5	(± 6.8)
51 and up	(69 and up)	±10 percent	

4.8.2. Tests/Verification

- 4.8.2.1. Prior to the start of the durability test, a sample closed valve of each size shall be hydrostatically pressurized to the rated working pressure for five minutes to verify that there is no seat or stem leakage. The sample valve shall then be installed in a flow line and cycled 1000 times through its full range of travel. Prior to the start of the durability test, the torque required at the handwheel shall be measured by opening the closed valve against rated working pressure, and closing the valve against the flow developed by a line velocity of 10 ft/sec (3.0 m/sec). During the test, the speed of rotation shall be approximately 1 cycle per minute. The manufacturer shall provide either a means to operate the valve, or an adapter to

connect to FM Approvals' test equipment (See Appendix D) to facilitate the application of 1000 cycles. At the conclusion of 1000 cycles, the torque to operate the valve shall again be measured as stated above.

- 4.8.2.2 Following this test, the valves shall be subjected to the stem and seat leakage tests detailed above.
- 4.8.2.3 The valve shall then be disassembled, and all moving parts shall be visually examined for signs of excessive wear or damage.

Table 4.8.2. Durability Flow Rates, 10 ft/sec (3.0 m/sec)

<i>Nominal Valve Size in.</i>	<i>Flow</i>	
	<i>gal/min</i>	<i>(L/min)</i>
1	25	(95)
1-1/4	45	(170)
1-1/2	65	(245)
2	105	(395)
2-1/2	150	(570)
3	230	(870)
3-1/2	310	(1175)
4	395	(1495)
5	625	(2365)
6	900	(3405)
8	1560	(5905)
10	2460	(9310)
12	3525	(13 345)

4.9 Close Quarters Durability Test - Butterfly Type

4.9.1 Requirements

The valve shall be capable of withstanding the water flow dynamics of installation at the discharge of an elbow. Representative samples of the indicating butterfly valve product line shall be installed at the discharge of an elbow and subjected to the flow rate resulting in a line velocity of 20 ft/sec (6.1 m/sec) in Schedule 40 pipe of the same nominal size. For the purposes of this test, the elbow shall be defined as having a center to end dimension as shown in Table 4.9.1A for grooved connections and Table 4.9.1B for threaded connections, or smaller radius. The input torque to open and close the valve shall be recorded at each orientation shown in Figure 4.9.2. Subsequently, the valve will be subjected to a water velocity of 20 ft/sec (6.1 m/sec) for a period of 60 minutes while in the full OPEN position. The valve shall be installed and tested in each of the orientations shown below. The manufacturer is given the option of using separate valves for each orientation, or using the same valve for both orientations. At the end of the flow test, the valve shall show no signs of failure, functional impairment, and shall comply with the Seat Leakage requirements of Section 4.3.

Table 4.9.1A Dimensions for Grooved Elbow Connections

Valve Size NPS	Center to End Dimension	
	in.	(mm)
2	3.25	(82.5)
2-1/2	3.75	(85.5)
3	4.25	(108.0)
3-1/2	4.50	(114.5)
4	5.00	(127.0)
5	5.50	(149.5)
6	6.50	(165.0)
8	7.75	(197.0)
10	9.00	(228.5)
12	10.00	(254.0)

Table 4.9.1B Dimensions for Threaded Elbows

Valve Size NPS	Center to End Dimension	
	in.	(mm)
1	1.50	(38.0)
1-1/4	1.75	(44.5)
1-1/2	1.94	(49.5)
2	2.25	(57.0)

4.9.2 Test/Verification

Prior to the start of the close quarter durability test, the valve shall be subjected to the Seat Leakage test described in Section 4.3. The valve shall then be installed in either orientation shown in the figures below and opened against rated working pressure and closed against the flow developed by a line velocity of 20 ft/sec (6.1 m/sec). The input torque readings shall be taken three times and averaged. The valve shall be then cycled to the full OPEN position and the water velocity shall be set to 20 ft/sec (6.1 m/sec) for a period of 60 minutes. At the conclusion of the flow test, the valve shall be removed from the flow line and cycled from OPEN to CLOSE to OPEN without signs of sticking, binding, or functional impairment as a result of the test. Subsequently, the valve shall be subjected to the Seat Leakage test described in Section 4.3. Repeat the test for the same size valve in the second orientation.

Figure 4.9.2 Close Quarter Durability Orientations

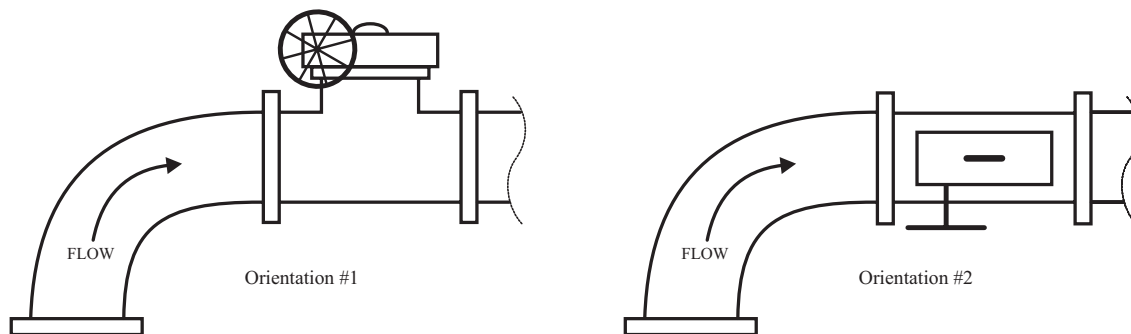

4.10 Friction Loss Determination

4.10.1 Requirement

The construction of the valve shall be such that obstruction to the passage of water through the valve body is minimal. With the ball or disc in the full open position, the loss in pressure through the valve shall not exceed 5.0 psi (35 kPa) at a flow producing a velocity of 20 ft/sec (6.1 m/sec) in Schedule 40 steel pipe of the same nominal diameter as the valve.

4.10.2 Tests/Verification

Tests shall be conducted to show that the friction loss through each nominal size valve does not exceed 5.0 psi (35 kPa) at the flow rates shown in Table 4.10.2. These flows have been calculated based on a fluid velocity of 20 ft/sec (6.1 m/sec) in Schedule 40 steel sprinkler pipe. This test may be waived at the examining engineer's option if drawing and calculation reviews of manufacturer's flow data are satisfactory. (Note: For valves larger than 12 in. nominal size, it shall be the responsibility of the manufacturer to submit friction loss data or calculations showing compliance.) For valves corresponding to metric sizes, the manufacturer shall indicate the metric pipe to be used in the evaluation.

Table 4.10.2. - Friction Loss Flows, 20 ft/sec (6.1 m/sec)

Nominal Valve Size in.	Flow	
	gal/min	(L/min)
1	55	(210)
1-1/4	95	(360)
1-1/2	125	(475)
2	210	(795)
2-1/2	300	(1135)
3	460	(1740)
3-1/2	615	(2330)
4	795	(3010)
5	1245	(4715)
6	1800	(6815)
8	3120	(11 810)
10	4915	(18 605)
12	7050	(26 685)

4.11 Visibility

4.11.1 Requirements

The indicator shall clearly show the disc or ball position at distances up to 10 ft (3 m) for valves 2-1/2 in. nominal size or smaller, and at 50 ft. (15 m) for larger sizes, when viewed by an informed observer. It shall not be necessary for the observer to be able to read the lettering to determine that the valve is open.

4.11.2 Tests/Verification

A sample valve shall be placed indoors under a light source generating approximately 50 lumen/ft² (538 lux). The indicator shall be in either the open or close position, but the valve disc or ball shall not be visible. At different times, at least four observers who have 20/20 vision (normal or corrected) and knowledge of the correct relationship between an indicator and connecting pipe, shall stand 10 ft (3 m) from a valve 2-1/2 in. nominal size and smaller, or 50 ft (15 m) from a valve 3 in. nominal size and larger, and attempt to determine whether the valve is open or closed. Their view will be blocked while the target indication is changed. Each will correctly identify the position of the disc or ball by observation of the indicator.

4.12 Orientation

4.12.1 Requirement

The valve and indicator shall be designed such that the parts can be assembled in only one orientation. The orientation of the indicator to the disc or ball shall be maintained at all times.

4.12.2 Tests/Verification

One or more sample valves shall be disassembled and attempts made to reassemble the parts with the indicator and disc or ball improperly oriented (90° out of phase) to each other. It shall be impossible to accomplish this.

4.13 Handwheel or Crank Strength

4.13.1 Requirement

The handwheel or crank shall be capable of withstanding a 300 lb (136 kg) force applied normal to the plane of rotation at a point along its perimeter or outer extremity. No damage shall occur as a result of this test.

4.13.2 Tests/Verification

The handwheel or crank shall be subjected to a 300 lb (136 kg) force normal to the plane of rotation and at a point along its perimeter or outer extremity (See Figure 4.13.2).

Figure 4.13.2 - Handwheel or Crank Strength

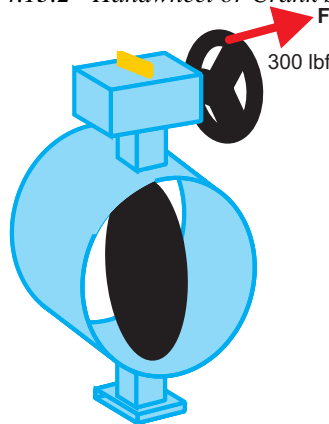

4.14 Water Hammer

4.14.1 Requirement

No water hammer shall occur when representative sample valves are closed as rapidly as possible at a flow producing a velocity of 20 ft/sec (6.6 m/sec) in Schedule 40 steel pipe of the same nominal pipe size as the valve.

4.14.2 Tests/Verification

In the presence of a flow rate producing a line velocity of 20 ft/sec (6.6 m/sec) in Schedule 40 steel pipe of the same nominal pipe size as the valve, the sample valves shall be manually closed as quickly as possible. No evidence of water hammer shall be observed. Valves with gear type operators that require more than 10 turns to close are acceptable.

4.15 Indicator Strength

4.15.1 Requirement

The indicator shall be able to withstand sudden impacts without fracturing or breaking or losing alignment with respect to the ball or disc position.

4.15.2 Tests/Verification

For each nominal size valve a 5 lb (2.3 kg), 2 in. (50 mm) diameter, cylindrical steel weight with a B-tup profile as defined in ASTM D2444, *Standard Test Method for Determination of the Impact Resistance of Thermoplastic Pipe and Fittings by Means of a Tup (Falling Weight)*, shall be dropped from a height of 10 ft (3 m) onto the indicator. There shall be no fracturing, breaking, or changing in alignment between the indicator and the ball or disc position as a result of this test. The test shall be conducted so that the weight falls directly onto the top of the indicator with the valve in the vertical orientation, as if the valve is installed in a horizontal run.

4.16 Water Absorption Test - Resilient Seated Valves Only

4.16.1 Requirement

For resilient seated valves, sealing surfaces shall not exceed water absorption limits specified in Section 4.16.2.

4.16.2 Tests/Verification

A specimen of the valve sealing surfaces supplied by the manufacturer shall be maintained in water at a temperature of 212 °F (100 °C) for 6 hours. The comparative ability of the sealing material to withstand the effect of water shall be evaluated in accordance with ASTM D 471, *Standard Test Method for Rubber Property - Effect of Liquids*. At the end of this period, any change in the sample shall not exceed 1.5 percent of the original thickness or weight.

4.17 Aging Test

4.17.1 Requirement

For resilient seated valves, aging shall not promote cracking of facings.

4.17.2 Tests/Verification

A specimen of the valve rubber facing, approximately 1 in. x 3 in. (25 mm x 75 mm), supplied by the valve manufacturer shall be subjected to an accelerated aging test in accordance with ASTM D 572 - *Standard Test Method for Rubber - Deterioration by Heat and Oxygen*. The test duration shall be 96 hours. After the test the specimen shall be examined for resilience. No cracking shall occur when the sample is bent double, (i.e. 180° outside bend radius of 2 times the material thickness).

4.18 Corrosion Protection Coating

4.18.1 Requirement

All materials used as corrosion resistant coatings that are required to ensure effectiveness of the valve seal shall resist separation from the corrosion protected material. No evidence of separation of the coating material from the base material, such as blistering, peeling, flaking, or delaminating shall result.

4.18.2 Test/Verification

Four test coupons, of the same material as the valve body, supplied by the valve manufacturer, prepared from cylindrical tubes measuring 6 inches (152 mm) in diameter by 4 inches (102 mm) long and split lengthwise shall be coated. On each sample an ‘‘X’’ of at least 2 in. (51 mm) length on each leg shall be scribed with a sharp instrument through the coating material to the metal substrate on both the inside and outside surfaces. The scribed test coupons shall then be immersed in a non-reactive container of deionized water at a temperature of 38°F (3°C) for 30 days. The samples shall be arranged so that they do not come in contact with the container or other samples. Following this test, the water temperature shall be raised to 150°F (66°C) and the same test coupons shall remain immersed for an additional 30 days. At the conclusion of this testing the coupon shall then be visually examined to determine if blistering, peeling, flaking or delaminating has occurred.

4.19 Submerged Service

4.19.1 Requirement

Valves that are to be located in pits shall operate properly when submerged for prolonged periods.

4.19.2 Tests/Verification

Valves intended for submerged service shall be subjected to long term exposure in simulated sea water. The valve shall be submerged for 6 months in simulated sea water compounded of 2.7 percent sodium chloride, 0.4 percent magnesium chloride, 0.2 percent magnesium sulfate, 0.1 percent calcium sulfate and 96.6 percent deionized water by weight. On completion of the test the maximum torque required to operate the valve shall be within the operating torque variance shown in Table 4.8.1 of the original test valve as determined in Section 4.6.2.1. The maximum torque shall be determined as performed in Section 4.6.2.1.

4.20 Supervisory Switches - Activation

4.20.1 Requirements

The switch shall activate before the handwheel has been rotated 2 full turns from its full OPEN position.

4.20.2 Tests/Verification

Manually cycle valve from OPEN to CLOSE noting where the switches activate.

4.21 Supervisory Switches - Cyclic

4.21.1 Requirement

The switch shall continue to activate after being subjected to 1000 cycles while under full electrical load. For reference, one cycle is considered OPEN to CLOSE to OPEN. Following this test the switch shall activate before the handwheel has been rotated 2 full turns from its full OPEN position.

4.21.2 Test/Verification

The valve shall be cycled 1000 times under full electrical load, where one cycle is OPEN to CLOSE to OPEN. Following the cycling the valve shall be manually cycled from OPEN to CLOSE, noting where the switches activate.

4.22 Supervisory Switches - Environmental

4.22.1 Requirement

The switch shall continue to activate following exposure to each of the environments shown in Tables 4.22.2a or 4.22.2b, depending on the valves intended use. Following this test the switch shall activate before the handwheel has been rotated 2 full turns from its full OPEN position.

4.22.2 Test/Verification

The switch shall continue to activate after 24 hours exposure to each of the environments shown in Table 4.22.2a for valves intended for indoor service only and Table 4.22.2b for valves intended for indoors or outdoor service. Following the environmental testing the valve shall be manually cycled from OPEN to CLOSE noting where the switches activate.

Table 4.22.2a Indoor Service Only

<i>Test Description</i>	<i>Parameters</i>	
	<i>°F</i>	<i>(°C)</i>
Cold Environment	32	(0)
Warm Environment	120	(49)
Humid Environment	100	(38)
	and 90 percent Relative Humidity	

Table 4.22.2b Indoor and Outdoor Service

<i>Test Description</i>	<i>Parameters</i>	
	<i>°F</i>	<i>°C</i>
Cold Environment	-40	(-40)
Warm Environment	140	(60)
Humid Environment	100 and 90 percent Relative Humidity	(38)

4.23 Supervisory Switches - Outdoor Service

4.23.1 Requirement

Indicating valves for outdoor service shall be subjected to a rain test. Following this test the gear operator cover shall be removed and the inside of the gear box shall be examined for signs of water entry. No water shall be allowed inside the gear operator as a result of this test.

4.23.2 Test/Verification

The top and all sides of the gear operator enclosure shall be subjected to the water spray created by three rain test spray nozzles when orientated as indicated in Figure 5-1, NEMA Standard 250-1997, *Enclosures for Electrical Equipment (1000 Volts Maximum)*. The supply water pressure shall be maintained at 5 psi (34.5 kPa) at each head for a period of one hour. The spray test heads shall comply with Figure 5-2 of NEMA Standard 250-1997, *Enclosures for Electrical Equipment (1000 Volts Maximum)* or equivalent as deemed by FM Approvals. Following the rain test the gear operator cover shall be removed and the inside of the gear box shall be visually examined for signs of water entry.

4.24 Supervisory Switches - Dielectric

4.24.1 Requirement

The switch shall withstand, for a time period one minute, high potential applied between the switch contacts and the valve enclosure (body), and between the switch contacts and the switch enclosure. During this test there shall be no signs of arcing or breakdown.

4.24.2 Test/Verification

The voltage, based on the switch rating, as shown in Table 4.24.2, shall be applied between the switch contacts and the valve enclosure (body), and between the switch contacts and the switch enclosure. This voltage shall be applied in each test for a duration of 1 minute. During the dielectric test there shall be no signs of arcing or breakdown.

Table 4.24.2 Dielectric Test

<i>Switch Ratings</i>	<i>Test Parameters</i>
24 Volt	500 Volts
60 Volt, or higher	1000 Volts + 2 * (AC Voltage if over 60 Volts)

4.25 Supervisory Switches - Vibration

4.25.1 Requirement

In order to determine the effect of vibration on the operation of the supervisory switches, samples of gear operators supplied with switches shall be subjected to a vibration test. The vibration test shall be conducted for a duration of 4 hours with the frequency continuously varying between 10 and 30 Hz. There shall be no observed loosening of assembly parts, breakage, or deformation as a result of this test.

4.25.2 Test/Verification

The gear operator shall be subjected to a vertical vibration with double amplitude displacement of 0.020 in. (0.5 mm) for 4 hours, with frequencies continuously varying between 10 and 30 Hz at a rate of 2 cycles per minute. Following the vibration test the switch shall activate before the handwheel has rotated 2 full turns from the full OPEN position. The gear operator cover shall then be removed to allow for a visual examination looking for loosening of assembly parts.

4.26 Supervisory Switches - Strain Relief

4.26.1 Requirement

The wiring shall be capable of supporting a load of 35 lbs (15 kg) without pulling out of the gear operator housing or resulting in damage to the switch itself, or assembled parts.

4.26.2 Test/Verification

A vertical load of 35 lbs (15 kg) shall be hung from the entire bundle of supervisory switch wiring for a period of 1 minute. Following this test the valve shall be visually examined for signs of movement of the switch relative to the gear operator or pull out of the wires from the housing or switch.

4.27 Supervisory Switches - Bonding Resistance

4.27.1 Requirement

The resistance measured between the grounding screw and/or terminal and various locations shall be less than 1 ohm.

4.27.2 Test/Verification

Using an ohmmeter, the resistance measured between the grounding screw and/or terminal and various locations on the gear operator and the valve body shall be measured.

4.28 Additional Tests

Additional tests, including performance tests of any accessories, may be required, depending on design features, results of any tests, material application, or to verify the integrity and reliability of the indicating valves, at the discretion of FM Approvals.

Unexplainable failures shall not be permitted. A re-test shall only be acceptable at the discretion of FM Approvals with adequate technical justification of the conditions and reasons for failure.

5. OPERATIONS REQUIREMENTS

A quality control program is required to assure that subsequent indicating valves produced by the manufacturer at an authorized location shall present the same quality and reliability as the specific indicating valves examined. Design quality, conformance to design, and performance are the areas of primary concern. Design quality is determined during the Approval examination and tests, and is covered in the Approval Report. Conformance to design is verified by control of quality and is covered in the Facilities and Procedures Audit (F&PA). Quality of performance is determined by field performances and by periodic re-examination and testing.

5.1 Demonstrated Quality Control Program

5.1.1 The manufacturer shall demonstrate a quality assurance program which specifies controls for at least the following areas:

- Existence of corporate quality assurance guidelines;
- Incoming quality assurance, including testing;
- In-process quality assurance, including testing;
- Final inspection and tests;
- Equipment calibration;
- Drawing and change control;
- Packaging and shipping;
- Handling and disposition of non-conformance materials; and,
- In order to assure adequate traceability of materials and products, the manufacturer shall maintain records of all quality control tests performed, for a minimum period of two years from the date of manufacture.

5.1.2 Documentation/Manual

There should be an authoritative collection of procedures and policies. Such documentation shall provide an accurate description of the quality management system while serving as a permanent reference for implementation and maintenance of that system. The system should require that sufficient records are maintained to demonstrate achievement of the required quality and verify operation of the quality system.

5.1.3 Drawing and Change Control

The manufacturer shall establish a system of product configuration control that shall not allow unauthorized changes to the product. Changes to critical documents, identified in the Approval Report, must be reported to, and authorized by, FM Approvals prior to implementation in production. The manufacturer shall assign an appropriate person or group to be responsible for reporting proposed changes to FM Approved products to FM Approvals before implementation. The manufacturer shall notify FM Approvals of changes in the product or of persons responsible for keeping FM Approvals advised by means of FM Approvals Form 797, Approved Product/ Specification-Tested Revision Report or Address/ Main Contact Change Report. Records of all revisions to all FM Approved products shall be maintained.

5.1.3.1 The listing below has been included as a guide to manufacturers of what is considered to be a significant change to FM Approvals. To facilitate the Approval of significant changes, modifications that fit this category should be documented by means of a letter stating the change, and requesting a quotation for an Approval examination.

<i>Modification</i>	<i>Description/Example</i>
Increase of Pressure Rating	The product was originally FM Approved for 175 psi (1205 kPa), and now is to be evaluated to 300 psi (2070 kPa).
Increase of Allowed Usage	The product was FM Approved for indoor locations only, and now is to be evaluated for use in outdoor service.
Addition of Product Sizes	The product was originally FM Approved for 1 – 4 inch NPS, and now Approval of 6 and 8 inch NPS is desired.
Addition or Relocation of the Manufacturing Location	The product was originally FM Approved as manufactured in location A, and now is desired to be made in locations A and B, or only in location B.
Addition of Alternate Suppliers for Purchased Items	Gear Operators, Encapsulated Discs, Valve Bodies, Supervisory Switches
Major Changes to Critical Dimensions, or Components	Modifications that would depart from the national or international standards that are used in the manufacturing of the product as originally FM Approved.
	Modifications that effect the Gear Operator such as: new gear ratio, alternate contact switches, significant revisions to sealing design (from O-Ring to flat gasket), etc.
	Modifications that effect the Valve such as: A reduction of body wall thickness in the pressure retaining areas, change in disc sealing arrangement (i.e. revision of the disc edge profile), significant changes in the ball or disc diameter, disc thickness, change in stem to disc connection, material changes to valve body, valve stem, disc or ball, etc.

5.1.3.2. The listing below has been included as a guide to manufacturers of modifications that are commonly submitted on FM Approvals Form 797.

<i>Modification</i>	<i>Description / Example</i>
Change in Company Contact Information	Name, Title, Phone Number, Fax Number, Email Address, Company Address, Company Name
Updating of Drawings	The Form 797 is used to notify FM Approvals in the event of: minor dimensional changes to non-critical features, minor changes in notes, location of title block, re-creation of the same drawing on CAD, etc.
Changes in Markings	Please describe what changes are to be made and include a drawing of the proposed marking.
Changes in Materials	Where new material is either of greater strength than, or comparable to material used in original Approval
Updating of Documentation	Creation of New or Revisions to Sales literature, Installation Instructions, Grooving Dimensions, Quality Manual, etc.

5.1.3.3 For the instances where the modification is difficult to categorize, manufacturers are encouraged to contact FM Approvals to discuss the nature of the change, and how to send the information to FM Approvals. The examples shown in Sections 5.1.3.1 and 5.1.3.2 are based on common examples of modifications as they relate to the manufacture of indicating valves.

5.1.3.4 FM Approvals, at its sole discretion, shall determine when additional testing is necessary to validate proposed changes.

5.2 Facilities and Procedures Audit (F&PA)

- 5.2.1 An audit of the manufacturing facility is part of the initial Approval investigation to verify implementation of the quality control program. Its purpose is to determine that the manufacturer's equipment, procedures, and quality program are maintained to insure a consistently uniform and reliable product. Initial inspections of facilities already producing similar products may be waived at the discretion of FM Approvals.
- 5.2.2 Unannounced follow-up inspections shall be conducted at least annually by FM Approvals, or its designate, to determine continued compliance. More frequent audits may be required by FM Approvals.
- 5.2.3 The client shall manufacture the product or service only at the location(s) audited by FM Approvals and as specified in the Approval Report. Manufacture of products bearing the FM Approved Mark is not permitted at any other locations without prior written authorization by FM Approvals.

5.3 Manufacturer's Responsibilities

- 5.3.1 The manufacturer shall notify FM Approvals of changes in product construction, design, components, raw materials, physical characteristics, component formulation or quality assurance procedures prior to implementation of such changes.
- 5.3.2 Where all or part of the quality control has been subcontracted, the manufacturer shall, at a minimum, conduct sufficient oversight audits to verify the continued application of the required controls.

5.4 Manufacturing and Production Tests

5.4.1 *Test Requirement No. 1 - Seat Leakage Test*

The manufacturer shall test 100 percent of production indicating valves for seat leakage to the rated working pressure. The test pressure shall be applied on the seat of a closed valve for a minimum of 15 seconds with leakage not exceeding 0.5 cm³ for metal-seated valves, and zero leakage for resilient-seated valves.

5.4.2 *Test Requirement No. 2 - Hydrostatic Test*

The manufacturer shall test 100 percent of production indicating valves for body leakage to twice the rated working pressure. The pressure shall be held for a minimum 1 minute with no evidence of body leakage or distortion.

5.4.3 *Test Requirement No. 3 - Operation Test*

The manufacturer shall perform an operation test on 100 percent of production indicating valves following the above seat leakage and hydrostatic test. All valves shall be opened through their full range of travel without evidence of sticking or binding. Verification of switch operation, if applicable, shall also be tested. Supervisory switches must activate within 2 complete revolutions of the handwheel from the full open position.

APPENDIX A: Units of Measurement

FLOW RATE:	gal/min - "gallons per minute"; (L/min - "liters per minute") L/min = gal/min x 3.785
LENGTH:	in. - "inches"; (mm - "millimeters") mm = in. x 25.4 ft - "feet"; (m - "meters") m = ft x 0.3048
LIQUID:	oz - "ounces"; (cm ³ - "cubic centimeters") cm ³ = oz x 3.382 x 10 ⁻²
MASS WEIGHT:	lb - "pounds"; (kg - "kilograms") kg = lb x 0.4535
PRESSURE:	psi - "pounds per square inch"; (kPa - "kilopascals") kPa = psi x 6.8948
TEMPERATURE:	°F - "degrees Fahrenheit"; (°C - "degrees Celsius") °C = (°F - 32) x 0.556
TORQUE or MOMENT:	ft·lb _f - "foot pound-force"; (N·m - "Newton-meters") N·m = ft·lb _f x 1.356

APPENDIX B: FM Approvals Certification Marks

FM Approvals certifications marks are to be used only in conjunction with products or services that have been Approved by FM Approvals and in adherence with usage guidelines.



FM APPROVED mark:

Authorized by FM Approvals as a certification mark for any product that has been FM Approved. There is no minimum size requirement for the mark, but it must be large enough to be readily identifiable. The mark should be produced in black on a light background, or in reverse on a dark background.



Cast-On FM Approvals marks:

Where reproduction of the FM Approved mark described above is impossible because of production restrictions, use these modified versions of the FM Approved mark. There is no minimum size requirement for the mark, but it must be large enough to be readily identifiable.



FM APPROVED mark With "C" only:

Authorized by FM Approvals as a certification mark for any product that has been evaluated by FM Approvals in accordance with Canadian codes and standards. There is no minimum size requirement for the mark, but it must be large enough to be readily identifiable. The mark should be produced in black on a light background, or in reverse on a dark background.



FM APPROVED mark with "C" and "US":

Authorized by FM Approvals as a certification mark for any product that has been evaluated by FM Approvals in accordance with US and Canadian codes and standards. There is no minimum size requirement for the mark, but it must be large enough to be readily identifiable. The mark should be produced in black on a light background, or in reverse on a dark background.

USAGE GUIDELINES

All FM Approvals certification marks are the sole property of FM Approvals LLC (“FM Approvals”) and are registered or the subject of applications for registration in the United States and many other countries. They are for use only according to these guidelines.

FM Approvals certification marks may be used only on FM Approved products and related product packaging, in advertising material, catalogs and news releases. Use of FM Approvals certification marks on such material is not a substitute for use of the complete FM Approvals certification mark on FM Approved products and/or product packaging.

No FM Approvals certification mark or aspect thereof may be incorporated as part of a business name, Internet domain name, or brand name/trademark for products/product lines. This includes both design aspects (the FM Approvals “diamond,” etc.) and word aspects (“FM,” “Approved,” etc.). The use of any FM Approvals certification mark as a trademark is strictly prohibited.

The Approval Standard number or class number may not be incorporated as part of a business name, Internet domain name, or brand name/trademark for products/product lines. For example, a company may not say “ABC Company’s 4100 Fire Door is FM Approved”; the proper terminology is, “ABC Company’s Fire Door is FM Approved per Approval Standard 4100.”

FM Approvals certification marks, except for the FM Approvals Quality System Registration mark, may not be used on business stationery/cards/signage because this could mischaracterize the relationship with FM Approvals. Additionally, these items should not reference any FM Approvals certification mark.

Products or services may not be marketed under any mark or name similar to “FM Global,” “FM Approvals” or any of the FM Approvals certification marks. Further, products or services may not be marketed to imply a relationship beyond the scope of any Approval made by FM Approvals.

When an FM Approvals certification mark is used in advertising material or on product packaging, all material must reflect the specific circumstances under which the product was FM Approved. The material must clearly differentiate between products that are FM Approved and those that are not, and may not, in any way, imply a more substantial relationship with FM Approvals.

A company may not reference the intent to submit a product for Approval or the expectation that a company will have a certain product FM Approved in the future. For example, a company may not state, “Approval by FM Approvals pending” or “Approval by FM Approvals applied for.”

FM Approvals certification marks should not be preceded or followed by a qualifier that indicates a degree of certification or acceptability. For example, “exceeds,” “first” or “only” may not be used to qualify any FM Approvals certification mark.

Only original artwork issued by FM Approvals should be used. The FM Approvals certification marks should not be altered in any way other than to resize the artwork proportionately. Unacceptable uses of the marks include, but are not limited to, adding/deleting wording or artwork, reducing the artwork to an illegible size, animation or distortion.

The text of the FM Approvals certification marks may not be translated into any language other than English.

FM Approvals certification marks must appear in a size and location that is readily identifiable, but less prominent than the name of the owner of the certification or the manufacturer/seller/distributor of the certified products.

APPENDIX C: Sample Listing

All new and current listings in the Approval Guide will be reformatted to resemble the following sample.

Model Number	Product Type	Nominal Pipe Size, Inch	Rated Working Pressure, psi (kPa)	Remarks
AA1	Butterfly Valve, Wafer Type	4, 6, 8	175 (1205)	a, b, d
AB1	Butterfly Valve, Lug Style	4, 6, 8	175 (1205)	a, c, d, e
AC1	Ball Valve, Grooved Ends	2, 3, 4	300 (2070)	a, c, d
AD1	Ball Valve, Threaded Ends	1, 1-1/4, 1-1/2, 2	175 (1205)	a, b, d, f

Remarks:

- a. Available with supervisory switches
- b. FM Approved for indoor service only
- c. FM Approved for indoor and outdoor service
- d. FM Approved for aboveground installations only
- e. Body drilled and tapped for ANSI B16.5 Class 150 steel flanges
- f. End connections are threaded to ANSI B1.20.1 NPT

APPENDIX D: Durability Test Adapter

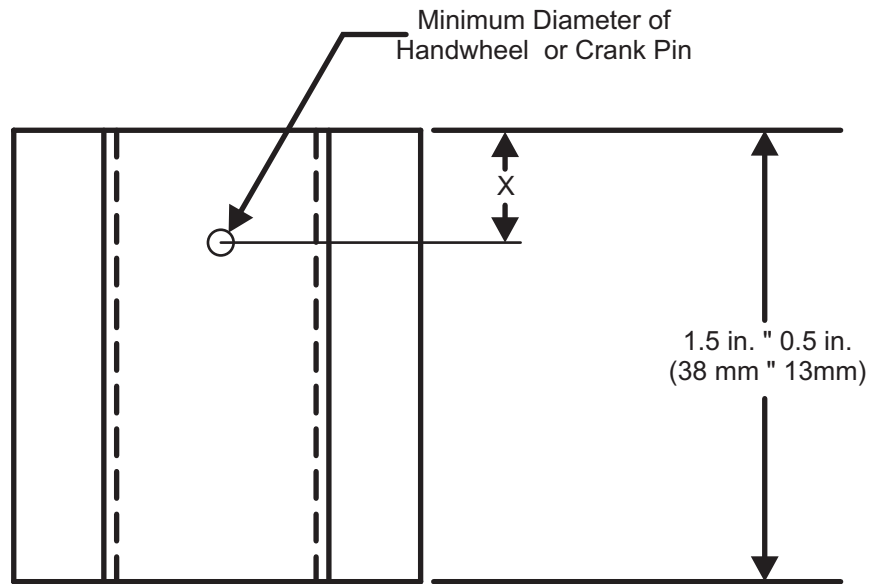
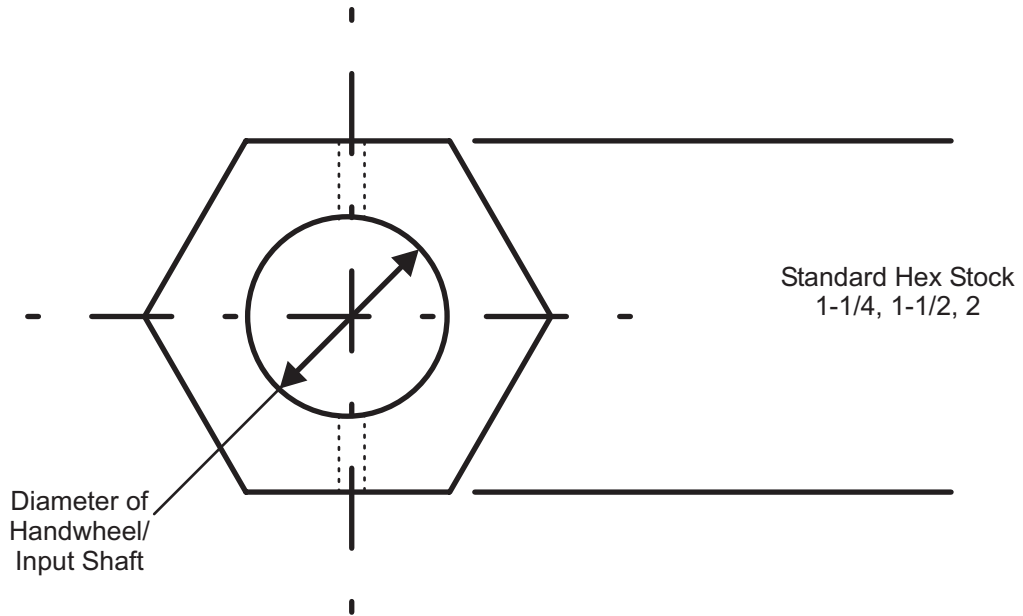

Where X equals the distance from the end of the handwheel shaft to the center of the handwheel retainer pin hole.

APPENDIX E: Tolerances

Unless otherwise stated, the following tolerances shall apply:

Flow	± 2 percent of value
Force	± 3 lbs of value
Frequency (Hz)	± 5 percent of value
Length	± 2 percent of value
Ohm	± 0.25 percent of value
Pressure	within $+ 5/- 0$ psi of value
Temperature	± 5 percent of value
Time	$+ 5/-0$ seconds $+ 0.1/-0$ minutes $+ 0.1/-0$ hours $+ 0.25/-0$ days
Volts	± 5 volts of value
Volume	± 5 percent of value

Unless stated otherwise, all tests shall be carried out at a room (ambient) temperature of $68 \pm 9^{\circ}\text{F}$ ($20 \pm 5^{\circ}\text{C}$).



Member of the FM Global Group

Printed in USA